

SAN FRANCISCO BAY AREA WATER EMERGENCY TRANSPORTATION AUTHORITY

SOUTH SAN FRANCISCO FERRY TERMINAL PIER STRUCTURES

ADDENDUM NO. 2

December 9, 2009

Pre-Proposal Meeting attendees and notes
Q&As
Modification to Pier Doors
Modification of Liquidated Damages Paragraph
Changes the date and time that technical proposals are due
Remove redundant specification section on coatings
Remove specification section on the steel gangway

SCOPE

This Addendum No. 2 consists of 3 pages and attachments. It does the following:

1. Provides a list of the attendees to the Pre-Proposal meeting held on December 1, 2009
2. Provides a list of questions and answers asked to date.
3. Replaces Specification Section 08700
4. replaces Plan Sheets P-11, P-13, P-14, P-25, P-26 and P-29.
5. Corrects statement regarding Liquidated Damages in Specification Section 01001.
6. Changes the date and time that proposals are due.
7. Removes Specification Section 09810 - Coatings from the contract documents.
8. Removes Specification Section 05650 Steel Gangway from the contract documents.

ATTENDEE LIST

See attached for the attendance list of the pre-proposal meeting held on December 1, 2009 at the Oyster Point Yacht Club.

QUESTIONS AND ANSWERS

See the attached questions and answers document. Note that the attached document does not differentiate between questions applying to package 2 and questions applying to package 3.

SECTION 08700 - REPLACEMENT

Replace original Specification Section 08700 in its entirety with the attached new Specification Section 08700.

PLAN SHEETS P-11, P-13, P-14, P-25, P-26 and P-29 - REPLACEMENT

Replace original Plan sheets P-11, P-13, P-14, P-25, P-26 and P-29 in their entirety with the attached new Plan Sheets P-11, P-13, P-14, P-25, P-26 and P-29.

SECTION 01001 - TIME FOR COMPLETION, LIQUIDATED DAMAGES, AND CONTRACTOR'S LICENSE - CORRECTION

For Paragraph 1.2.C. in Specification Section 01001;

Replace the following:

- C. No liquidated damages will be assessed under this contract.

With:

- C. The estimated cost impact to WETA of not having a functioning ferry terminal at Oyster point is \$5000.00 per day. This estimate is based on lease costs, idle equipment and personnel costs, loss of fare revenue and opportunity costs; and other factors. If the Ferry Terminal is not able to fully function as intended at the end of the Contract Time, WETA shall assess Contractor for these costs under the provisions for liquidated damages described in section 00700, General Provisions of these specifications. .

CHANGE TIME AND DATE THAT PROPOSALS ARE DUE

Proposals will be accepted until 2:00 PM on December 23, 2009.

1. Replace the following line in Section 00200, Appendix B::

Deadline for Offeror Submission of Technical Proposals December 18, 2009 at 12 pm

With:

Deadline for Offeror Submission of Technical Proposals December 23, 2009 at 2 pm

2. Correct Section 00100 – Notice Inviting Proposals

Change the first paragraph from:

"NOTICE IS HEREBY GIVEN THAT PROPOSALS will be received by the Manager, Planning and Development of the San Francisco Bay Area Water Emergency Transportation Authority (hereinafter "WETA") at Pier 9, Suite 111, San Francisco, CA 94111, until **2:00 p.m.** on **December 18, 2009** for the following project:"

To:

"NOTICE IS HEREBY GIVEN THAT PROPOSALS will be received by the Manager, Planning and Development of the San Francisco Bay Area Water Emergency Transportation Authority (hereinafter "WETA") at Pier 9, Suite 111, San Francisco, CA 94111, until **2:00 p.m.** on **December 23, 2009** for the following project:"

SPECIFICATION SECTION 09810 - COATINGS

Remove Specification Section 09810 - Coatings from the contract documents in its entirety. This section is redundant.

SPECIFICATION SECTION 05650 – STEEL GANGWAY

Remove Specification Section 05650 - Steel Gangway from the contract documents in its entirety. This steel gangway is not part of the pier structures contract.

ACKNOWLEDGMENT BY BIDDER

Each Offeror is required to acknowledge receipt of all Addenda, including this Addenda No. 2. as specified in the Instructions to Offerors.

ISSUED BY:

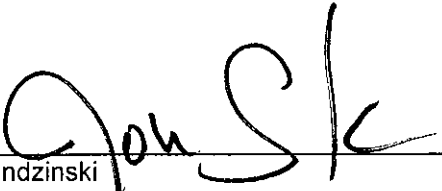

John Sindzinski
Manager, Planning and Development

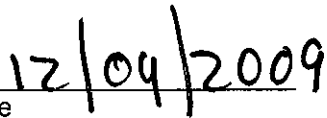

Date

Pier

Water Emergency Transportation Authority
 South San Francisco Ferry Terminal
 Pier / Float Gangway
Pre-Proposal Conference Attendee List, December 1, 2009

NAME	COMPANY	DBE	Float/ Gangway	Pier	PHONE	FAX	E-MAIL
KELLY BLYTHE	POWER ENG.	<input type="checkbox"/>	<input checked="" type="checkbox"/>	<input checked="" type="checkbox"/>	510-337-3800X235	510-337-3808	kblythe@power-engineering.net
ANDREA BOSTAPH	POWER ENG.	<input type="checkbox"/>	<input checked="" type="checkbox"/>	<input checked="" type="checkbox"/>	510-337-3800X237		bostaph@power-engineering.net
DAVID MIK	POWER ENG.	<input type="checkbox"/>	<input checked="" type="checkbox"/>	<input checked="" type="checkbox"/>	510-337-3800X218		mik@power-engineering.net
KEN LINDBERG	POWER ENG.	<input type="checkbox"/>	<input checked="" type="checkbox"/>	<input checked="" type="checkbox"/>	510-337-3800X231		kl@power-engineering.net
JASON SILVA	KEIWIT-GENERAL	<input type="checkbox"/>	<input type="checkbox"/>	<input type="checkbox"/>	206-793-0807		JASON SILVA@KIEWIT.COM
MARK EREKSON	KEIWIT-GENERAL	<input type="checkbox"/>	<input checked="" type="checkbox"/>	<input checked="" type="checkbox"/>	360-779-3200		MARK.EREKSON@KIEWIT.COM
GORDON LLOYD	RPE CONST.	<input type="checkbox"/>	<input checked="" type="checkbox"/>	<input checked="" type="checkbox"/>	415-822-6687	415-822-4716	RPECONST@NETSCAPE.NET
JOHN WHITE	SHIMMICK CONST.	<input type="checkbox"/>	<input checked="" type="checkbox"/>	<input checked="" type="checkbox"/>	510-777-5000	510-777-5099	jwhite@shimmick.com
DOUG WOODUILL	MANSON CONST.	<input type="checkbox"/>	<input checked="" type="checkbox"/>	<input checked="" type="checkbox"/>	510-232-6319		dwooduill@mansonconstruction.com
MATT SHANNAHAN	MANSON CONST.	<input type="checkbox"/>	<input checked="" type="checkbox"/>	<input checked="" type="checkbox"/>	510-773-7501		mshannahan@mansonconstruction.com
BK COOPER	GBI/CCR CONST. J/V	<input type="checkbox"/>	<input checked="" type="checkbox"/>	<input checked="" type="checkbox"/>	415-892-2778	415-892-9229	cooper@coopercrane.com
SARAH GARCIA	TURNER CONST.	<input type="checkbox"/>	<input checked="" type="checkbox"/>	<input checked="" type="checkbox"/>	510-267-8244	510-267-8118	sgarcia@tcco.com
DAN WHEELER	TURNER CONST.	<input type="checkbox"/>	<input checked="" type="checkbox"/>	<input checked="" type="checkbox"/>	510-267-8100	510-267-8119	drwheeler@tcco.com
CLINT LARISON	REYES CONST.	<input type="checkbox"/>	<input checked="" type="checkbox"/>	<input checked="" type="checkbox"/>	909-622-2259	909-622-3053	CLARISON@REYESCONSTRUCTION.COM
PETE RUTSCH	VORTEX MARINE CONST.	<input type="checkbox"/>	<input checked="" type="checkbox"/>	<input checked="" type="checkbox"/>	510-261-2400	510-261-2444	prutsch@vortex-sfb.com
STEVE CANADAY	BELLINGHAM MARINE	<input type="checkbox"/>	<input checked="" type="checkbox"/>	<input type="checkbox"/>	707-249-1641	707-678-1760	scanaday@bellingham-marine.com

Water Emergency Transportation Authority
 South San Francisco Ferry Terminal
 Pier / Float Gangway
Pre-Proposal Conference Attendee List, December 1, 2009

NAME	COMPANY	DBE	Float/ Gangway	Pier	PHONE	FAX	E-MAIL
DAN CHOW	DUTRA	<input type="checkbox"/>	<input checked="" type="checkbox"/>	<input checked="" type="checkbox"/>	415-258-1590	415-459-3295	dchow@dutragroup.com
CHARLES GEHLERT	DUTRA	<input type="checkbox"/>	<input checked="" type="checkbox"/>	<input checked="" type="checkbox"/>	415-258-6876 415-250 7523 cell	415-459-3295	cgehlert@dutragroup.com
IRA MAYBAUM	BAY SHIP & YACHT CO.	<input type="checkbox"/>	<input checked="" type="checkbox"/>	<input type="checkbox"/>	510-971-0298	510-337-0715	imaybaum@bay-ship.com
		<input type="checkbox"/>	<input type="checkbox"/>	<input type="checkbox"/>			
JENNIFER PECHACEK	HOLMES CULLEY STRUCTURAL ENG.	<input type="checkbox"/>	<input type="checkbox"/>	<input checked="" type="checkbox"/>	415-693-1600	415-693-1760	jpechacek@holmesculley.com
BILL TREMAYNE	HOLMES CULLEY STRUCTURAL ENG.	<input type="checkbox"/>	<input type="checkbox"/>	<input checked="" type="checkbox"/>	415-693-1601	415-693-1761	billt@holmesculley.com
STEVE HARDY	HALCROW STRUCTURAL ENG.	<input type="checkbox"/>	<input checked="" type="checkbox"/>	<input checked="" type="checkbox"/>	510-452-0040	510-452-0041	shardy@halcrow.com
OREN RUBIN	VBN ARCHITECTS	<input type="checkbox"/>	<input checked="" type="checkbox"/>	<input checked="" type="checkbox"/>	510-350-0099	510-250-0098	oren@vbnarch.com
LAMAR SCOTT	KPFF ENG.	<input type="checkbox"/>	<input checked="" type="checkbox"/>	<input checked="" type="checkbox"/>	206-382-0601		LSCOTT@KPFFSPD.COM
MING CHEN YU	AMC CONSULTING ENG.	<input checked="" type="checkbox"/>	<input checked="" type="checkbox"/>	<input checked="" type="checkbox"/>	415-738-6106	510-663-1119	mcyu@amcon.com
JAMES CONNOLLY	BEN C. GERWICK, INC CONSULTING ENG.	<input type="checkbox"/>	<input checked="" type="checkbox"/>	<input checked="" type="checkbox"/>	415-288-2764	415-398-0433	jmc@gerwick.com
GEORGE LO	BEYAZ & PATEL, INC CONSULTING ENG.	<input type="checkbox"/>	<input checked="" type="checkbox"/>	<input checked="" type="checkbox"/>	925-699-5290	925-934-0318	glo@beyazpatel.com
MOHAN SABAPATHY	TMAD TAYLOR & GAINES ENGINEERING	<input type="checkbox"/>	<input checked="" type="checkbox"/>	<input checked="" type="checkbox"/>	415-296-0100	415-296-0101	msabapathy@tmadtg.com
JENNIFER HUNG	CALLANDER ASSOC. ARCHITECTURE	<input type="checkbox"/>	<input checked="" type="checkbox"/>	<input checked="" type="checkbox"/>	650-375-1313	650-344-3290	jhung@callanderassociates.com
PETER CALLANDER	CALLANDER ASSOC. ARCHITECTURE	<input type="checkbox"/>	<input checked="" type="checkbox"/>	<input checked="" type="checkbox"/>	650-375-1314	650-344-3291	pcallander@callanderassociates.com
GRACE SARMIENTO	SUMMIT ASSOCIATES CONST. MANAGERS	<input checked="" type="checkbox"/>	<input checked="" type="checkbox"/>	<input checked="" type="checkbox"/>	925-363-5560	925-363-5511	grace.sarmiento@summitcm.com

Water Emergency Transportation Authority
 South San Francisco Ferry Terminal
 Pier / Float Gangway
Pre-Proposal Conference Attendee List, December 1, 2009

NAME	COMPANY	DBE	Float/ Gangway	Pier	PHONE	FAX	E-MAIL
BRUCE OSTBO	BERGER ABAM	<input type="checkbox"/>	<input checked="" type="checkbox"/>	<input type="checkbox"/>	206-431-2346	206-431-2250	bruce.ostbo@abam.com
BRYAN FRANK	THORTON TOMASETTI	<input type="checkbox"/>	<input checked="" type="checkbox"/>	<input checked="" type="checkbox"/>	510-433-9370	510-433-9378	bfrank@thortontomasetti.com
CRAIG LEWIS	WINZLER & KELLY	<input type="checkbox"/>	<input checked="" type="checkbox"/>	<input checked="" type="checkbox"/>	415-283-4970	415-283-4980	craiglewis@w-and-k.com
CARY RONAN	TREADWELL & ROLLO ENVIR. & GEO ENGIN.	<input type="checkbox"/>	<input checked="" type="checkbox"/>	<input checked="" type="checkbox"/>	415-955-9040X276	415-955-9041	CERONAN@TRESDWELLROLLO.COM
JOHN GOUCHOR	TREADWELL & ROLLO ENVIR. & GEO ENGIN.	<input type="checkbox"/>	<input checked="" type="checkbox"/>	<input checked="" type="checkbox"/>	408-551-6700X101	408-551-0344	JGOUCHON@TREADWELLROLLO.COM
JOHN SUMNICHT	SGH	<input type="checkbox"/>	<input type="checkbox"/>	<input type="checkbox"/>	415-495-3700	415-495-3550	JFSUMNICHT@SGH.COM
LISA SING	DCS	<input checked="" type="checkbox"/>	<input checked="" type="checkbox"/>	<input checked="" type="checkbox"/>	415-797-2322	415-494-5171	lisa@dcs-llc.com
BEN HAFNER	AEROTEK E&E	<input type="checkbox"/>	<input type="checkbox"/>	<input type="checkbox"/>	650-825-2967		bhafner@aerotek.com
HARRIE W YAGER	LOCAL 34 PILE DRIVERS	<input type="checkbox"/>	<input type="checkbox"/>	<input type="checkbox"/>	510-635-4227	510-635-1234	hyager@nccrc.org
PATRICK BARRETT	CEMENT MASONS OPCMIA 300	<input type="checkbox"/>	<input type="checkbox"/>	<input type="checkbox"/>	650-343-5671	650-348-3670	pbarrett@opcmllocal300.org
DAVE HARRISON	OPERATING ENGINEERS LOCAL 3	<input type="checkbox"/>	<input type="checkbox"/>	<input type="checkbox"/>	707-429-5008	707-429-0729	dharrison@oe3.org

Q1: Who is the contact person for the project?

A1: John Sindzinski is the contact person – all contact information is in the information on the notice.

Q2: When is the start date?

A2: We plan to have our Board of Directors award the contract in February with the project starting in March/April. Please be mindful of insurance requirements as they may be potentially difficult to meet. Please bring up any issues earlier than later. Some of the insurance requirements have been passed down to us from one of our funding agencies, so we would like to get feedback on how this works for you.

Q3: When is the estimated completion date?

A3: In the summer of 2011.

Q4: What is the time frame?

A4: The contract duration will be determined by the schedule provided in the Offeror's proposal. See Specification Section 00200 - Instruction to Offerors, Appendix C. Para II.4.a.

Q5: Are there calculations available for designs today?

A5: Engineering calculations will not be provided until the competitive range is determined.

Q6: Will the project drawings be distributed to the selected team in an AutoCAD format?

A6: Yes with caveats and the requirement that a waiver release be signed.

Q7: Will the project specifications be distributed to the selected team in a WORD format?

A7: WETA will provide the project specifications in WORD format to the selected team after award with caveats and a requirement that a waiver release form be signed.

Q8: Does a design team need to regenerate all the drawings?

A8: No, we will provide the electronic design files to the successful Offeror with some caveats and the requirement that a waiver release form be signed. The existing drawings will therefore, not need to be recreated however, we want an independent review of all the drawings and as this is a design build project, it will be the contractor's responsibility to review all of the drawings. We want your creative experience and input.

Q9: Can we change the design?

A9: Yes but the owner is not obligated to accept proposed changes. . The specifications identify those aspects that are given and those which are not.

- Q11: Can locations of manhole covers or canopy columns be adjusted on the float?
A11: Changes in design, such as relocation of manhole covers, may be allowed if specifically approved by WETA through a formal question and response process. Owner is not obligated to accept proposed changes.
- Q12: Will we be allowed to modify the material selections that are specified in the current Specification package or to modify the required coatings?
A12: Changes in design, such as material selection, may be allowed if specifically approved by WETA through a formal question and response process. Owner is not obligated to accept proposed changes.
- Q13: The 2" potable water system is specified as 304SS. It is our experience that 304SS will corrode in a marine environment. Do you want to change the piping material to 316SS or fusion epoxy coated piping?
A13: The material for the 2" potable water shall be 316SS
- Q14: The 3" sanitary sewer is schedule 80 pvc. Is the district concerned with debris damaging the plastic pipe? If so, do you want to shift to 316SS or fusion epoxy coated piping system?
A14: The 3" schedule 80 PVC pipe is acceptable for this location. 316SS is a good/better solution and is also acceptable.
- Q15: The 6" diameter dry standpipe is specified as galvanized steel pipe where exposed to air. It is our experience that galvanized steel will corrode in a marine environment. We would recommend 316SS, ductile iron, or possibly fusion epoxy coating over the originally specified material.
A15: We accept the recommended upgrade to 316SS.
- Q16: Is the size of the float a set design?
A16: Yes, the size of the float is set, unless there is a significant reason to revisit the design. We do not anticipate changing the size of the float however, we will consider changes to the design if there are real and concrete reasons for doing so. These designs have gone through significant engineering review but would of course, benefit from one last review by the offeror's design team.
- Q17: Do we need supporting documents if we make changes?
A17: Yes.
- Q18: Is there a reason why the agency is using a bridged design? It seems expensive to bring in another wave of design review.
A18: We have found this to be a very beneficial process. The design build process provides for more diverse input on the project and often shortens the time frame.
- Q19: What are the benefits of a 90% design in a Design-Build contact?

- A19: The design documents, as stated in the RFP, are at various levels of completion. We have found that allowing the input from the Design Build Contractor to be beneficial and ultimately leads to a more effective and efficient process.
- Q20: Some of the drawings are at 80% and some are at 60%, so we are wondering what aspects of the design are firm, and what aspects are variable?
- A20: The bid documents state quite clearly that certain aspects are givens and others are changeable. If you change any aspect, we expect that you make it very clear what was changed and why.
- Q21: Has there been a coastal Engineering analysis for this project?
- A21: Yes, it is incorporated into the contract documents.
- Q22: Have the project drawings been “Plan Reviewed” by the City of South San Francisco Building Department at any stage in the design?
- A22: There has been a pre-application review by the City’s Building and Fire Departments. However, the Design-Build Contractor is required to make a formal application for a building permit and to secure the permit prior to beginning construction.
- Q23: Does this project have any State of California funds? If so, will the Division of the State Architect require a review and approval for accessibility?
- A23: Yes there are state funds. No, Department of the State Architect approval is not required.
- Q24: Are independent Material Testing and Special Inspections included in the contract work?
- A24: Specification Section 01400 addresses this question.
- Q25: Who is doing contractor compliance?
- A25: Ghirardelli Associates and WETA.
- Q26: What are the hours of operation? Does that need to be spelled out in the proposal?
- A26: Hours of operations will be governed by the City of South San Francisco and the San Mateo Harbor District noise ordinances. Under those ordinances, the working hours for construction are generally 8 AM to 8PM except on Sundays and holidays when it is 10 AM to 6 PM.
- Q27: What are the formal bid protest procedures? Are there any requirements to protest?
- A27: You must bid on the project to be able to protest. The formal protest requirements are in the bid documents. See specification section 00200 paragraphs 4.G. and 4.H.
- Q28: Will you be providing copies of your sign in sheet?
- A28: Yes. We will scan and post them on the web.

Q29: Can the contractor rely on sizing of piles for pricing? What can we rely on for pricing?

A29: We have indicated to the permitting agencies the size of the piles etc, so yes, it is pretty specific. Obviously if there is a major reason to change them, then yes, we will consider changing that aspect of the design. You can rely on the sizes of the piles that are in the specifications for creating your price proposal.

Q30: For your DBE goal, does that include subcontractors to subcontractors?

A30: Yes.

Q31: What agency(s) is approved to certify DBE's?

A31: WETA will accept current DBE certification from the California Unified Certification Program (CUCP) available at www.dot.ca.gov/ucp <<http://www.dot.ca.gov/ucp>> .

Q32: Is pricing required on December 18th?

A32: Technical Proposals are due at 2:00pm on December 23, 2009. Firms in the competitive range will be asked to submit a price proposal at a later date. See specification section 00200.

Q33: Do we need to include a schedule with our proposal? How detailed does that need to be? Will we be held to the deadlines we submit based on this preliminary information?

A33: The schedule needs to be detailed enough to demonstrate that you are knowledgeable in this type of work. Your initial schedule will be used to determine the contract duration which will be a factor in evaluating your proposal. Specific internal milestones and task details will be set when the more detailed schedule is provided during the pre-award process. See Specification Section 00200 - Instruction to Offerors, Appendix C. Para II.4.a.

Q34: Is it the contractors' responsibility to dispose of waste off-site? For example, what if we found hazardous waste/contaminated materials?

A34: We do not anticipate any hazardous waste unless the Contractor brings it onto the site. If pre-existing hazardous or contaminated materials are encountered on site during the work, the Design-Build Contractor will not be the Generator. WETA will provide an EPA Waste Identification number, and will sign waste manifests as appropriate. Please note that portions of this site are a landfill and the Contractor must do everything possible to prevent penetrating the clay landfill cap.

Q36: Section 00200 "Instructions to Offerors", part 2B "Examination of Documents and Work Site" references to assumption of liability by the Contractor regarding subsurface and hazardous materials. Please confirm that if pre-existing hazardous or contaminated materials are encountered on site during the work that the Design-Build Contractor will not be the Generator, and that WETA will provide

- an EPA Waste Identification number, and will sign all waste manifests as appropriate.
- A36: If pre-existing hazardous or contaminated materials are encountered on site during the work, the Design-Build Contractor will not be the Generator, and that WETA will provide an EPA Waste Identification number, and will sign all waste manifests as appropriate.
- Q37: If we encounter hazardous materials from here, wouldn't that mean we are the generator of the waste?
- A37: The property owner will be the "Generator".
- Q38: Omitted.
- Q39: Specification Section 200, Appendix C, II-4-b refers to "Major Participants." Does the proposing team determine who constitutes a "Major Participant" or is there a dollar threshold or scope of work to determine this definition?
- A39: See Specification Section 00200 Paragraph 8.C. This applies to any subcontractor to whom the Offeror proposes to subcontract portions of the work in an amount in excess of one-half of one percent of the Total Price or \$10,000, whichever is greater.
- Q40: In Bid Package 2, steel Specification Sections 5120, 5500, 5520, and 5710, Fabrication, it calls out for the steel to be galvanized and prime painted per Section 9960. Top coats are not referenced. In Section 9960 there is no schedule of finishes or when they are to be applied. The section also notes (9960-2.1-B—1) that colors will be supplied by the owner's rep. Is it the district's expectation for the project team to develop the final coating specification? If so, will galvanizing still be a requirement?
- A40: At a minimum, all steel will be galvanized, primed and finished the metal paint specified in Specification Section 09960. Specific substitutions may be allowed following a formal request from the Contractor and response by WETA.
- Q41: Who is responsible for the "monitoring" requirements spelled out in the project environmental permits (pile driving monitoring, oyster density monitoring, etc.)?
- A41: The Contractor is responsible for meeting the applicable permit requirements. The owner will provide Quality Assurance over the Contractor's efforts.
- Q42: Will the district (*WETA?*) consider allowing a second round of questions for the teams selected to provide pricing in Step 2 of the proposal? If so, will alternate substitutions also be considering during Step 2, the Price Proposal?
- A42: Questions directly related to preparation of a pricing proposal will be allowed between selection of the competitive range and acceptance of price proposals. Material substitutions may be proposed during this time but the Owner is under no obligation to accept or approve them. Substitutions of team members during this period will not be allowed.

- Q43: Section 0860-1.06 requires Professional Liability Insurance (errors and omissions) with limits of \$1million per claim or occurrence. Professional Liability Insurance is purchased on a "Claims Made" option only, not an "Occurrence Basis." Will a "Claims Made" policy be acceptable for design professionals on the project?
- A43: If the requirement can not be met, Offeror's insurance provider must so certify in written form and WETA will seek exceptions from the funding agency prior to awards.
- Q44: Can WETA clarify what agency or agencies will have jurisdiction over the approval of the ramp lift system and also inform bidders whether or not WETA has started the approval process with whichever agency has jurisdiction? It has been Reyes Construction's experience that in certain cases it is necessary for state agencies to approve the configuration of ramp lift systems associated with floating docks. When approval falls under jurisdiction of a state agency the approval process can last for an extended period of time. In order for bidders to more accurately determine construction costs and construction durations please clarify this issue.
- A44: The Design-Build contractor is responsible for compliance with applicable regulations and permitting requirements. WETA is unaware of requirements for state agency review of the float ramp lift system and has not started such a review process.
- Q45: Can you please speak more precisely as to what you are looking for with each requested matrix (Instructions to Offerors, 00200-C-4; Section II.4.c)? Am I to take the work "matrix" literally with the Participants listed along the x-axis and the responsibilities along the y-axis? (Similarly with the Responsibility Matrix and the Personnel Matrix in the paragraphs immediately following)? Would a well-organized list suffice?
- A45: Where a matrix form is provided in the RFP it should be used. The RFP describes the requirements for completing the matrices. Where a form is not provided and a matrix is called for, the Offeror may choose the form and composition of the matrix. Examples of ways to present the information might include an organized list or a spreadsheet showing participants along one axis and responsibilities, experience or other data along the other axis.
- Q46: The RFP states that bids are due at 2pm on 12/18/09, but the full schedule listed in Appendix B says they are due at noon. Please clarify.
- A46: See change in addendum 2. Bids are due at 2 PM on 12/23/09.
- Q47: Colloquially, an organization is different from a company, in that the former tends to be a public agency and the latter tends to be a private one. Are you making such a distinction when stating that we must get References from 5 organizations? Must References come from public Owner agencies or may they be from private owners, or even from General Contractors to whom we performed

- major work as a Subcontractor (despite that we would be bidding this job as a prime)?
- A47: The word “Organization” is to be interpreted in the broader fashion. It includes federal, state and local government entities as well as firms, companies, or other commercial and non-profit entities. It may also include private individuals, families or foundations.
- Q48: You ask for fairly thorough subcontractor information as part of the Team Qualifications as well as part of the Offeror's own experience with Subcontractors as part of the Technical Proposal. How do you propose that we best fulfill this requirement, since we will be soliciting Contractors--DBEs in particular--throughout the Pricing Phase, which follows?
- A48: Offerors are responsible for assembling the teams in their technical proposals. The technical proposal will be used to evaluate which Offerors are in the competitive range and it is up to each Offeror to determine how their team is to be constituted.
- Q49: Are subcontractors, vendors and suppliers only identified in step 2 of the evaluation process?
- A49: The team submitted for step one is the team that is being evaluated. You should identify your entire team for the December 18 submittal.
- Q50: Section 00200 of the South San Francisco Ferry Terminal Pier Structures Package 2 RFP, section 4b, page C-4 requires that references be provided as part of the technical proposal. Due to the time challenges associated with the USPS, is it acceptable for our references to fax or e-mail the completed reference forms to WETA?
- A50: Fax or PDF attachments to e-mails are acceptable. Address for any such e-mails shall be Sindzinski@watertransit.org and must be from the person who wrote the evaluation.
- Q51: Can or will digital copies of the RFP documents be made available to the Offerors? Specifically, the forms that are required to be submitted in steps 1 and 2.
- A51: The forms will be available on the WETA website.
- Q52: Could I please pick up or get a disc mailed with the plans & specs in order to save time and money over obtaining them through the BPS web site?
- A52: The plans and specifications are available for all Offerors through the BPS web site or through the Bay Area Builder's Exchanges/Plan Rooms. WETA will not distribute the documents directly to potential Offerors.
- Q53: Section 00200 of the South San Francisco Ferry Terminal Pier Structures Package 2 RFP, section 4b, page C-3 requests that experience for Offerors and Major Participants on relevant projects over the last 10 years be provided as part of the technical proposal. Can the experience limit be extended to 15 years?

- A53: Both relevancy and currency are important. For the section of the proposal cited in the question, please limit the project list to those that occurred over the last 10 years.
- Q54: Section 00200 of the South San Francisco Ferry Terminal Pier Structures Package 2 RFP, section 4b, page C-3 requests that experience for Offerors and Major Participants on relevant projects over the last 10 years be provided as part of the technical proposal. Please confirm that 5 projects for each participating entity of the Design-Build team is a sufficient quantity to be submitted provided that they are relevant.
- A54: Companies should show enough relevant experience to differentiate themselves from other firms competing for inclusion within the competitive range.
- Q55: Will WETA accept proposals that are printed 2-sided?
- A55: The specified proposal format neither requires nor restricts 2-sided printing.
- Q56: Section 00200 of the South San Francisco Ferry Terminal Pier Structures Package 2 RFP, sections 4d and 4e, page C-5 requests Offerors to provide copies of Environmental and Safety/Injury & Illness Prevention Plans. Due to the large size of these documents, is it acceptable to include this information digitally only on the CD provided with the proposals – specifically the Corporate Environmental Policy and Company Safety and Illness Prevention Plan.
- A56: CD's of these documents in PDF or MSWord format are acceptable if there is a copy attached to each paper proposal and at least one complete paper copy of the documents is submitted. This does not relieve the requirement for a separate CD containing the entire proposal.
- Q57: Specification section 05650 of the South San Francisco Ferry Terminal Pier Structures Package 2 RFP refers to *design, fabrication, and installation of a steel truss gangway*. Please confirm that this specification section is provided in package 2 only for coordination purposes and that design, fabrication, and installation of a steel truss gangway is clearly in the scope of work for package #3.
- A57: Specification section 05650 is provided in package #2 for coordination purposes only. Design, fabrication, and installation of a steel truss gangway are in the scope of work for package #3. For clarity, addendum 2 removes this section from the Pier Structures specifications.
- Q58: Drawing S-3 "General Notes", "Statement for Special Inspections", in section "D" of the South San Francisco Ferry Terminal Pier Structures Package 2 RFP specifically states that continuous inspection during installation of augur-cast pile will be needed on this project however, no augur-cast pile are shown in the drawings and there is not a specification section for augur-cast pile included in the documents. Please confirm that there is no augur-cast pile on this project.
- A58: The current design does not use auger cast or CIDH piles.

- Q59: Please refer to page 4 of Enclosure 2 of the NOAA letter included in Addenda #1 which references that 20-30 Ea. 24" concrete pile will be required for the new docking facility. The drawings and specifications for packages #2 and #3 do not indicate concrete pile. Please confirm that there are no concrete pile in packages #2 and #3.
- A59: Confirmed. No such piles are currently designed into packages #2 & #3. The piles for the Viewing Terrace are 24" diameter, concrete-filled piles, not concrete piles. The 24" concrete piles referred to are guide piles for existing facilities and for package # 1.
- Q60: Please refer to sheet S-11 which provides a table and notes pertaining to piling for the pier including pile diameters, wall thicknesses, and end of pile conditions indicating that pier pile are open-ended. No such table exists for the pile under the viewing terrace however, details 5 and 6 on Sheet S-7 indicate that viewing terrace pile are 24" dia. X ¾" wall closed tip pile. Please confirm that the design intent is to have 2 different pile end conditions within package #2.
- A60: Confirmed.
- Q61: The permits provided in Addenda #1 indicate that there are seasonal work limitations for dredging pertaining to Central California Coast steelhead and Pacific hearing however, the only limitations stated for pile driving are the noise and vibration limitations. Please confirm that there are no seasonal limitations or restrictions on this project that would limit pile-driving operations to specific times of year.
- A61: The permits do not require seasonal restrictions if vibratory pile driving methods are used.
- Q62: Please refer to the BCDC Permit No. 1-08 included as part of Addenda #1. Will the Riprap referenced in Section "F" be in place as part of package #1 prior to the anticipated start of construction for packages #2 and #3? Is this the existing riprap referenced from sheet S-10?
- A62: The BCDC permit refers to riprap that is in place.
- Q63: Is it necessary to submit two separate proposals? If pursuing both may we submit one proposal?
- A63: Offerors must submit a proposal for each package on which they wish to compete. Each package will be a separate contract. Each proposal received will be evaluated against the selection criteria for one package.
- Q64: If Offeror is planning to submit for both packages, are they required to submit all forms twice?
- A64: Offerors must submit a complete proposal for each package on which they wish to compete. Each package will be a separate contract. Each proposal received will be evaluated against the selection criteria for one package. Proposals that do not contain complete information will be deemed non-responsive.

Q65: How does WETA wish an Offeror to submit value engineering, alternative design and proposed enhancements?

A65: These should be submitted after award.

Q66: What is the Owner's organization Chart?

A66: Project Manger is John Sindzinski, WETA; Owner's Designate Representative is Bill Davis, Ghirardelli Associates; Owner's Lead Design Consultant is Boris Dramov, Roma Design Group.

Q67: In Step 2 of the process, may we submit multiple trade contractors for competitive bidding purposes?

A67: Both the technical and the price proposals shall include the team that the Offeror intends to use on the project.

Q68: Bid package 2, Specification Section 2367-2.2.A requires the pile steel be prepared to SSPC-SP-6. Specification Section 9810-2.3B requires the steel to be prepared to SSPC-SP-10. Which specification section is correct?

A68: SSPC-SP-10

Q69: Package 2, drawing S-1, Note 5: Earthquake Design Data shows a Seismic Importance Factor of 1.5. Please clarify the basis for this decision.

A69: This is Specified by Owner – no clarification required.

Q70: Package 2, drawing S-1, Note 5: Earthquake Design Data: Viewing Terrace has a Response Factor, R that is not specified. Can you provide that factor?

A70: Viewing Terrace is assumed to be a Rigid Non-Building Structure – Ref:ASCE-7, Section 15.4.2. There is no R value.

Q71: Package 2, drawing S-1, Note 5: Earthquake Design Data: Push Over Analysis has a Performance Objective of IO at DE, LS at MCE. From what Criteria Document is the District taking strain and deformation levels?

A71: Earthquake Design Data:

- Seismic Importance Factor: 1.5 (Essential Facility)
- Mapped Spectral Response:
 - Ss: 1.64 g
 - S1: 0.83 g
- Site Class: E
- Spectral Response Coefficients:
 - Sds: 0.98 g
 - Sd1: 1.33 g
- Seismic Design Category: F
- Analysis Procedure: Pushover analysis. Model includes steel piles to depth of at least 85 ft with non-linear soil springs as provided by the Geotechnical Engineer.
- Design Standard: ASCE 41-06, Supplement No. 1
- Maximum Credible Earthquake (MCE): 2% probability of occurrence in 50 years.

- Design Earthquake (DBE): 2/3 MCE
- Performance Objective:
 - Immediate Occupancy at DBE
 - Life Safety at MCE
- Acceptance Criteria: ASCE 41-06, Supplement No. 1

Load Combinations: Per ASCE 7-05 – Strength Design.

Q72: Package 2, drawing S-1, Concrete Notes requires #5 and smaller rebar to have 2” clear. ACI 318 requires 3” clear for all rebar on marine facilities. Do you want this note changed?

A72: Yes

Q73: Package 2, drawing S-6 shows the approach slab having beam and slab construction. Can we use a flat slab? This is easier to form and provides less corners to reduce corrosion potential.

A73: An equivalent flat slab will probably weigh more than the slab and beam system. As long as the additional weight is accommodated in the gravity and lateral design, we have no objection.

Q74: Package 2, drawing S-7, Detail 3 also shows 2” of clearance on rebar. Is this correct?

A74: If cast against earth, the clearance should be 3”.

Q75: Package 2, drawing S-14, Details 3 & 7 show old style hoops for shear reinforcement. Do you want to change to more efficient headed reinforcing?

A75: No.

Q76: Specification Section 3100 doesn’t address installing temporary support piles for dock formwork. Will they be allowed considering the desire not to penetrate the cap over the landfill?

A76: No piles will be allowed where they will penetrate the cap.

Q77: Section 16131 of the specifications, Part 3, paragraph 3.1.A.1 states that galvanized rigid steel conduit is allowed in “damp and wet locations.” Is this correct or should the conduit be coated in damp and wet locations such as under the pier

A77: Galvanized Rigid steel conduit, in damp and wet locations, shall be 40 mil PVC coated.

Q78: Specification Section 9810-2.2.A requires a minimum DFT of 5 mils. What is the total minimum required DFT?

A78: Follow the manufacturer’s recommendations with a minimum DFT of 5 mils per coat.

Q79: Package 2, Sheet T-3: What is “R” on the joints in Detail 1?

- A79: 2R indicated on the plan detail 1 refers to the number of stair risers.
- Q80: Package 2, drawing P-32: The vertical steel bar mullions are shown as curved and segmented for the same window assembly. Please clarify whether the mullions are curved or segmented.
- A80: The vertical steel bar mullions are curved the windows are segmented.
- Q81: Package 2, drawing P-22 and Detail 1, P-32: The sloped windows as currently detailed create valleys where water will pool and present prolonged exposure to water penetration and corrosion of the steel. It is recommended that the perimeter sealant be built and tooled to a slope, so as to act as a shed for standing water. This should be applied to all such sloped window details. Will this be acceptable?
- A81: Yes, it is acceptable
- Q82: Package 2, drawing P-25, Details 1, 4, 5, and 8: The doors are currently drawing with no immediate vertical framing, using instead the steel vertical posts. It is recommended that a door frame from the manufacturer be introduced in order to facilitate typical fabrications such as door hinges, electrical wiring, and to address any clearance issues against the structural steel framing. This can be made from the same stainless steel material as the door leafs. Will this be acceptable?
- A82: Yes, the approach of using a stainless steel door frame would be acceptable subject to review of the specific proposed details.
- Q83: Package 2, drawing P-21, Detail A and 3: There is a 1/8" bent plate flashing shown on the 8" x 4" HSS beam. Is there a preferred attachment method by the owner (welded, mechanically fastened)?
- A83: Mechanically fastened.
- Q84: Package 3, drawing G-4, Elevations 1 and 2 show a toe kick. However, Page G-6 details 1 and 2 do not show a toe kick. Please confirm whether a toe kick is required.
- A84: A toe space is shown on both drawings and is required.
- Q85: Package 3, Specification Section 8800-2.1.B.3: Polyvinyl buteral core (PVB) inner-layer will suffer against exposure to the air and moisture resulting in delamination bubbles at the glass edge. The PVB inner layer should be replaced with a Urethane inner-layer if the glass edge is to be exposed. Is this change acceptable or is the PVB inner layer required?
- A85: Yes, this is acceptable and desirable.
- Q86: Package 3, drawings F-2 shows an east-west offset dimension from the edge of float to the center of the corner dolphins as 3'0". The same dimension is shown as 1'0" on drawing S-1. Which is correct?
- A86: Locate the piles so that the outside face of the donut fender aligns with the face of the knee fender on the corner of the float.

- Q87: Package 3, drawing F-15 shows 2' 1-1/2" from top of float deck to bottom of HSS member supporting the movable ramp in the ramp's down position. Drawing MR-3 shows 2' 3" from the top of the float deck to the top of the ramp walkway surface in the down position. Which is correct?
- A87: This dimension is determined by the 1:12 slope from the fixed access ramp down the sloped access ramp to the moveable transfer ramp. The important dimension is the walking surface elevation and not the distance to the float deck because it varies from center of float to edge. A ramp of 21'-3/4" length goes up and down 1'-9" with a 1:12 slope. The 7'-0" freeboard of the fixed access ramp \pm 1'-9" gives a freeboard of 5'-3" in the lower position and 8'-9" in the upper position. These dimensions are also noted on Sheet F-10 Note 3.
- Q88: Package 3, drawing F-15 has a similar conflict in the up position. Which dimensions govern?
- A88: This dimension is determined by the 1:12 slope from the fixed access ramp down the sloped access ramp to the moveable transfer ramp. The important dimension is the walking surface elevation and not the distance to the float deck because it varies from center of float to edge. A ramp of 21'-3/4" length goes up and down 1'-9" with a 1:12 slope. The 7'-0" freeboard of the fixed access ramp \pm 1'-9" gives a freeboard of 5'-3" in the lower position and 8'-9" in the upper position. These dimensions are also noted on Sheet F-10 Note 3.
- Q89: Package 3, Specification Section 2488, paragraph 1.4.B: which live load shall be used to check the 2 degree float heel; the ramp load in paragraph 1.5.C.2.a or the deck load in paragraph 1.5.C.2.b?
- A89: The live load of 100 PSF shall be placed on the Access Ramps (paragraph 1.5.C.2.a.) on one side of the float to check the 2 degrees float heel.
- Q90: In Bid Package 3, we have done preliminary calculations on the heel of the concrete float with an applied 100PSF LL per Section 02488-1.4B. Based on our preliminary calculation, the heel will be greater than the 2 degrees specified but less than the 9 degrees of heel allowed by the USCG. If we limit the 100PSF LL to only the service platform areas, the 2 degree heel constraint works. Was a more limited live load application the intention of the specification?
- A90: The live load of 100 PSF shall be placed on the Access Ramps (paragraph 1.5.C.2.a.) on one side of the float to check the 2 degrees float heel.
- Q91: Package 3, Specification Section 2488, paragraph 1.5.C.2.b: is it the intent of this paragraph that the 100psf deck load "shall" not be combined with the ramp load in paragraph 1.5.C.2.a? To say that it "need not" implies that it could be combined.
- A91: The two live load cases in 1.5.C.2.b are (1) 100 psf over the entire float, and (2) 100 psf over the exposed deck plus concentrated live loads resulting from 100 psf on the Access Ramps.

- Q92: Package 3, Specification Section 2488, paragraph 1.5.C.3: Are the environmental loads given in the table also intended to represent the maximum delivery voyage conditions when the float is moved from the SSF site to the Alternative Site?
- A92: The Contractor is not responsible for relocation of this float to an alternative location. The Contractor is responsible for transport of the float to the South San Francisco Ferry Terminal site and must determine appropriate criteria for this transport.
- Q93: Package 3, Specification Section 3380, paragraph 1.6.A and 3.1.C require pre-stress to vary from the maximum at the float bottom slab to zero stress at the top. Is the designer required to adhere to this requirement even if the environmental conditions given in Section 2488 result in excessive stresses at the deck surface under hog wave loading conditions?
- A93: The Design Build Contractor is required to confirm stresses are acceptable for all conditions.
- Q94: Package 3, Specification Section 1200, paragraph 1.2.C.1 states that the dolphin pile size shown on the drawings is the minimum size to be used. The dolphin pile on drawing F-11 is 42" diameter; on S-20 it is 36" diameter. Which drawing is correct?
- A94: Drawing S-20 is correct.
- Q95: For the weight of the Hollow Metal Stainless Steel Clad Doors would Horton's 4100 Low Energy Power Operator be acceptable in Lieu of Horton's 7000 as specified?
- A95: The requirement has been changed from Horton 7000 to 4100. See change specification and drawing changes attached to Addendum 2 for the Package 2 RFP.
- Q96: All of the Horton Power Swing Operators are 6" High in Lieu of 4 1/2" as specified, is this acceptable?
- A96: 6" is acceptable. See change specification and drawing changes attached to Addendum 2 for the Package 2 RFP.
- Q97: Center Hung Doors cannot Swing 180 Degrees as shown, as they will be stopped by the jamb. We have been able to Swing Doors 180 Degrees by using Horton's 4100 Power Swing Operator on the pull side of the Doors and using a Custom Arm arrangement. Please clarify.
- A97: Doors have been relocated to be flush with HSS TS to allow 180° swing. See change specification and drawing changes attached to Addendum 2 for the Package 2 RFP.
- Q98: The 2007 California Building Code January 1, 2009 Supplement, calls for Two Activation Push Plates per side for ADA Doors. Is it acceptable to use Wikk Industries Ingress'r Activating Column or Two Push Plates Mounted High and low on a Wikk Bollard/Post?

A98: The requirements have been changed to provide two push plates. See change specification and drawing changes attached to Addendum 2 for the Package 2 RFP.

Q99: Sheet P-12, shows S.S. Handicapped Door Paddle Switches and Card Readers Mounted on a Square, are these Stainless Steel Bollard/Posts. Please clarify.

A99: Bollards are Stainless Steel.

Q100: Section 16131 of the specifications, Part 3, paragraph 3.1.A.1 states that galvanized rigid steel conduit is allowed in “damp and wet locations.” Is this correct or should the conduit be coated in damp and wet locations such as under the pier?

A100: Galvanized rigid steel conduit, in damp and wet locations, shall be 40 mil PVC coated.

Q101: When can we submit approved equal substitution requests?

A101: Teams that are determined to be within the competitive range may submit these types of request until 10 days before price proposals are due.

SECTION 08700

HARDWARE

PART 1 - GENERAL

1.1 SUMMARY

- A. Section Includes: Provide hardware for stainless steel doors and for steel doors.
- B. Related Sections:
 - 1. Section 08110: Steel doors and frames.
 - 2. Section 08112: Stainless steel doors.
 - 3. Section 08510: Steel windows including window hardware.

1.2 REFERENCES

- A. ANSI A115 Series: Door and Frame Preparation Standards.
- B. ANSI A156.1 through A156.20: Standards for various hardware items.
- C. California Building Code: California Code of Regulations, Title 24, Part 2.
- D. Americans with Disabilities Act Accessibility Guidelines (ADAAG).

1.3 SYSTEM DESCRIPTION

- A. Products: Provide each type of hardware (hinges, pivots, locksets, latchsets, closers, trim) from single manufacturer unless otherwise indicated in Hardware Schedule.
 - 1. Provide products by manufacturers specified and manufacturers listed in Hardware Schedule, with references to catalog numbers and designations.
- B. Access for Persons with Disabilities: Comply with California Building Code and Americans with Disabilities Act Accessibility Guidelines (ADAAG).

1.4 SUBMITTALS

- A. Product Data: Submit catalog cuts for each type of hardware.
- B. Shop Drawings: Indicate locations and mounting heights of hardware.
 - 1. Supply templates to door and frame manufacturers for proper and accurate sizing and locations of cut-outs for hardware.
- C. Wiring Diagrams: Submit for electrically activated hardware.
- D. Samples: Indicate required style and finish of exposed door hardware.
- E. Keying Schedule: Coordinate directly with Owner's Representative.

1.5 QUALITY ASSURANCE

- A. Supplier Qualifications: Recognized builder's hardware supplier with minimum five year's successful experience in scheduling and furnishing hardware.
 - 1. Provide services of architectural hardware consultant to supervise hardware supply.
- B. Pre-Installation Meeting: Convene pre-installation meeting prior to commencing work of this section. Include persons involved with installation of doors, frames, and hardware.

1.6 DELIVERY, STORAGE, AND HANDLING

- A. Deliver hardware in manufacturer's original packages, marked for intended opening and use.
- B. Pack complete with necessary screws, bolts, keys, instructions, and installation template, if necessary, for spotting mortising tools.
- C. Upon delivery, furnish complete list of hardware for checking, clearly marked to correspond with marking on each package.
 - 1. Review list for completeness and accuracy.

1.7 MAINTENANCE

- A. Provide manufacturer's parts list and maintenance instructions for each type of hardware supplied and necessary wrenches and tools required for proper maintenance of hardware.

PART 2 - PRODUCTS

2.1 MATERIALS

- A. General: Review Drawings for hardware group locations and door types; where not fully covered in Hardware Schedule, comply with following general requirements; inform Owner's Designated Architectural Representative where conflicts occur.
 - 1. Provide hardware items with accessories complete to function as intended.
- B. Hinges and Butts: ANSI A156.1; comply with following unless otherwise indicated.
 - 1. Manufacturers:
 - a. Hager Hinge Co.
 - b. Lawrence Brothers Inc.
 - c. McKinney Products Co., Division of Essex Industries.
 - d. Stanley Hardware Division of Stanley Works.
 - e. Substitutions: Refer to Section 01630.
 - 2. Type: Extra heavy weight ball or oilite bearing; 4-1/2" for doors up to 41" wide, 5" for doors from 42" to 48" wide.
 - a. Provide widths sufficient to clear trim projection when door swings 180 degrees.
 - 3. Provide minimum 3 hinges (1-1/2 pair) per door leaf for doors up tot 7'-5", 4 hinges (2 pair) per door leaf for doors over 7'-5".
 - 4. Provide butts with non-removable corrosion resistant Type 316L stainless steel pins.
 - 5. Tips: Flat button tips with matching plug.

- C. Locking Devices: Provide of metal matching specified finish; interior parts of steel and zinc-dichromate plating, to resist rusting and corrosion; do not supply plastic, die-cast or aluminum mechanisms.
1. Manufacturers:
 - a. Von Duprin, Inc.
 - b. Sargent Manufacturing Co.
 - c. Dorma Group North America.
 - d. Precision Hardware Division of Stanley Hardware.
 - e. Substitutions: Refer to Section 01630.
 2. Exit/Panic Devices: ANSI A156.3, Grade 1, with 6 pin tumbler cylinders, except where otherwise indicated in Hardware Schedule; maximum 15 lbs. operating force.
 - a. Type: Mortise device with concealed vertical rods unless otherwise indicated.
 - b. Style: Modern.
 3. Design: As selected by Owner's Designated Architectural Representative from manufacturer's full range of designs.
 4. Backset: 2-3/4".
 5. Strikes: Furnish standard strikes with extended lips where required to protect trim from being marred by latch bolt; verify type of cutouts provided in metal frames.
- D. Cylinders, Keys, and Keying: Hardware manufacturers shall provide for grand master, master key alike or key different keying as directed by Owner.
1. Manufacturer: Match existing system as directed by Owner.
 2. Provide cylinders of extruded brass bar material.
 3. Provide construction cylinders for doors requiring locking during construction; construction cylinders shall be removed and replaced just prior to Owner occupancy.
 4. Submit keys for final use to Owner; provide not less than five keys for each lockset.
- E. Low Energy Door Operators: Complete operator system including door operator, controls, and attachment system designed for type of doors indicated and complying with requirements of ANSI A156.19 for low energy power operated door operators. Contact: AD Troyer & Associates, Gary Troyer (650) 871-4202.
1. Manufacturers:
 - a. Record-USA/8500 Series.
 - b. Horton Automatics/Series 4100.
 - c. LCN/4600 Series Electrically Powered Auto-Equalizer.
 - d. Dor-O-Matic, Inc./Senior-Swing Automatic Operation.
 - e. Substitutions: Refer to Section 01630.
 2. Controls: As indicated, as selected by Owner's Designated Architectural Representative from manufacturer's full range of flush wall mounted push-button control units where not otherwise indicated.
- F. Thresholds, Door Stops, Flush Bolts, Trim, and Miscellaneous Hardware: Provide as indicated, as specified, as included in Hardware Schedule, and as required for complete installation.

1. Manufacturers:
 - a. Rutherford.
 - b. Trimco, Triangle Brass Mfg. Co.
 - c. Rockwood.
 - d. Glynn Johnson.
 - e. Pemko.
 - f. Ives.
 - g. Trimco.
 - h. Manufacturers listed on Hardware Schedule.
 - i. Substitutions: Refer to Section 01630.

2.2 ACCESSORIES

- A. General: Provide complete hardware with accessories as required for doors and applications indicated.
- B. Templates: Furnish templates or physical hardware items to manufacturers concerned sufficiently in advance to avoid delay in Work.
- C. Reinforcing Units: Furnished by door manufacturer, coordinated by hardware manufacturer.
- D. Fasteners: Furnish as recommended by manufacturer and as required to install secure hardware.
 1. Finish: Match hardware.
 2. Furnish screws for items applied on gypsum board sufficiently long to provide solid connection to framing or backing
- E. Through Bolts: Through bolts and grommet nuts shall be avoided on door faces in highly visible areas, unless no alternative is possible, as directed and approved, and shall not be used for solid wood core doors.
- F. Electrical and Mechanical: Make provisions and coordinate requirements for mechanical and electrical devices in connection with hardware.

2.3 FINISHES

- A. Provide following finishes except where otherwise indicated.
- B. Typical: BHMA 630 (US32D), satin finished stainless steel.
- C. Other Items: Provide manufacturer's standard finishes matching similar hardware types on same door, and maintain acceptable finish considering anticipated use.

PART 3 - EXECUTION

3.1 INSTALLATION

- A. Install finish hardware specified under this section; coordinate with manufacturer and installation of doors and frames.
- B. Fit hardware prior to painting. Remove for painting of doors and frames before final installation of hardware.

- C. Install hardware in accordance with manufacturer's instructions.
- D. No extra cost will be allowed because of changes or corrections necessary to facilitate installation of hardware.

3.2 MOUNTING POSITIONS

- A. Heights given are center line heights from finished floor.
 - 1. Locks and Latches: 38" to center of lever.
 - 2. Door Pulls: 42" to center of grip.
 - 3. Push Plate: 42"; coordinate with pull location.
 - 4. Push-Pull Bar: 42" to center of bar.
 - 5. Top Hinge: To jamb manufacturer's standard, but not greater than 10" from head of frame to center line of hinge.
 - 6. Bottom Hinge: To jamb manufacturer's standard, but not greater than 12-1/2" from floor to center line of hinge.
 - 7. Intermediate Hinges: Equally spaced between top and bottom hinges and from each other.
 - 8. Hinge Mortise on Door Leaf: 1/4" to 5/16" from stop side of door.
 - 9. Dead Bolt: Not more than 44" from floor to operating lever.
- B. Comply with recommendations of Builders Hardware Manufacturers Association, subject to approval, for heights of items not indicated.

3.3 ADJUSTING AND CLEANING

- A. Qualified hardware supplier's or manufacturer's representatives shall inspect installation and make adjustments.
 - 1. Adjust closers, locks, and critical operational hardware.
 - 2. Deliver instructions for maintenance and future adjustments to Owner's Representative.
- B. Cleaning: Clean hardware just prior to Substantial Completion using cleaning materials and methods recommended by hardware manufacturer; do not damage hardware or adjacent materials.

3.4 HARDWARE SCHEDULE

- A. The Hardware Schedule establishes a type and standard of quality.
- B. Examine Drawings and Specifications and furnish proper hardware for door openings, whether listed or not.
- C. Bring omissions to attention of Owner's Designated Architectural Representative prior to bid opening for instructions; otherwise, list will be considered complete; no extras will be allowed.
- D. Hardware Groups General: Base bids on manufacturers' items specified for locks, closers and panic devices.

1. Client is seeking bidders' best price on these items.
2. After acceptance of original bid based on items specified, other manufacturers may be presented for cost saving purposes only, or at the direct request of Owner and Owner's Designated Architectural Representative.
3. In some cases, quantity (*) of hinge pairs will vary with height of door (see Hardware Section Preamble).

E. Hardware Groups:

Hardware Set for Stainless Steel Doors

*	Pair Hinges	BB1199 Stainless Steel	Hager
2	Cylinders	As directed by Owner	
2	Exit Devices	EL3347NL-OP	Von Duprin
2	Transfer Hinges	EPT-10	Von Duprin
1	Power Booster	PS872	Von Duprin
2	Power Assist Operators	8500 concealed in frame w. H.O	Record
4	Buttons (in walls)	950HP6 Stainless Steel	Rutherford
1	Bollard Post (6" square)	For doors at P9 & P10 Stainless Steel	WIKK
1	Key Switch	960N-MA to allow Continuous Retraction of Exit Devices	Rutherford
1	Pull	RM3311 80"	Rockwood
2	Door Stops	1209 w. hook	Trimco

Hardware Set for Doors at Electrical Cabinets

*	Pair Hinges	BB1199 Stainless Steel	Hager
1	Deadbolt	B560P	Schlage
2	Pulls	1111C	Trimco
1	Flush Bolt	FB611	Ives
1	Dust Proof Strike	DP2	Ives
1	Astragal	355AU or by Door Manufacturer	Pemko
2	Door Stops (Overhead)	ADJ-100	A&B, Glynn Johnson

END OF SECTION

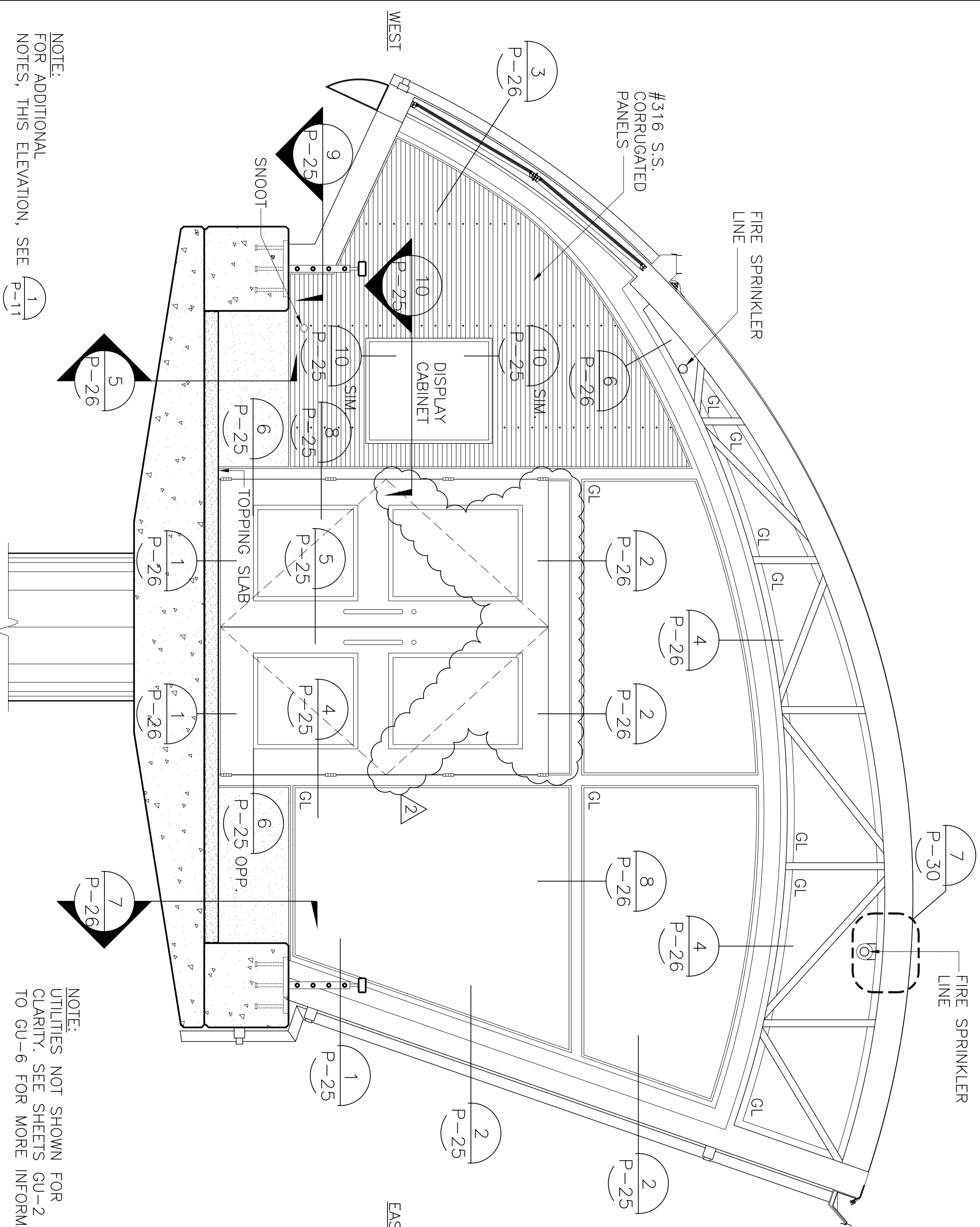

NOTE:
UTILITIES NOT SHOWN FOR
CLARITY. SEE SHEETS GU-2
TO GU-6 FOR MORE INFORMATION.

NOTE:
FOR ADDITIONAL
NOTES, THIS ELEVATION, SEE 

 PIER SOUTH ENTRY/EGRESS ELEVATION – LOOKING NORTH @ GRIDLINE P1
SCALE 1/2" = 1'-0"

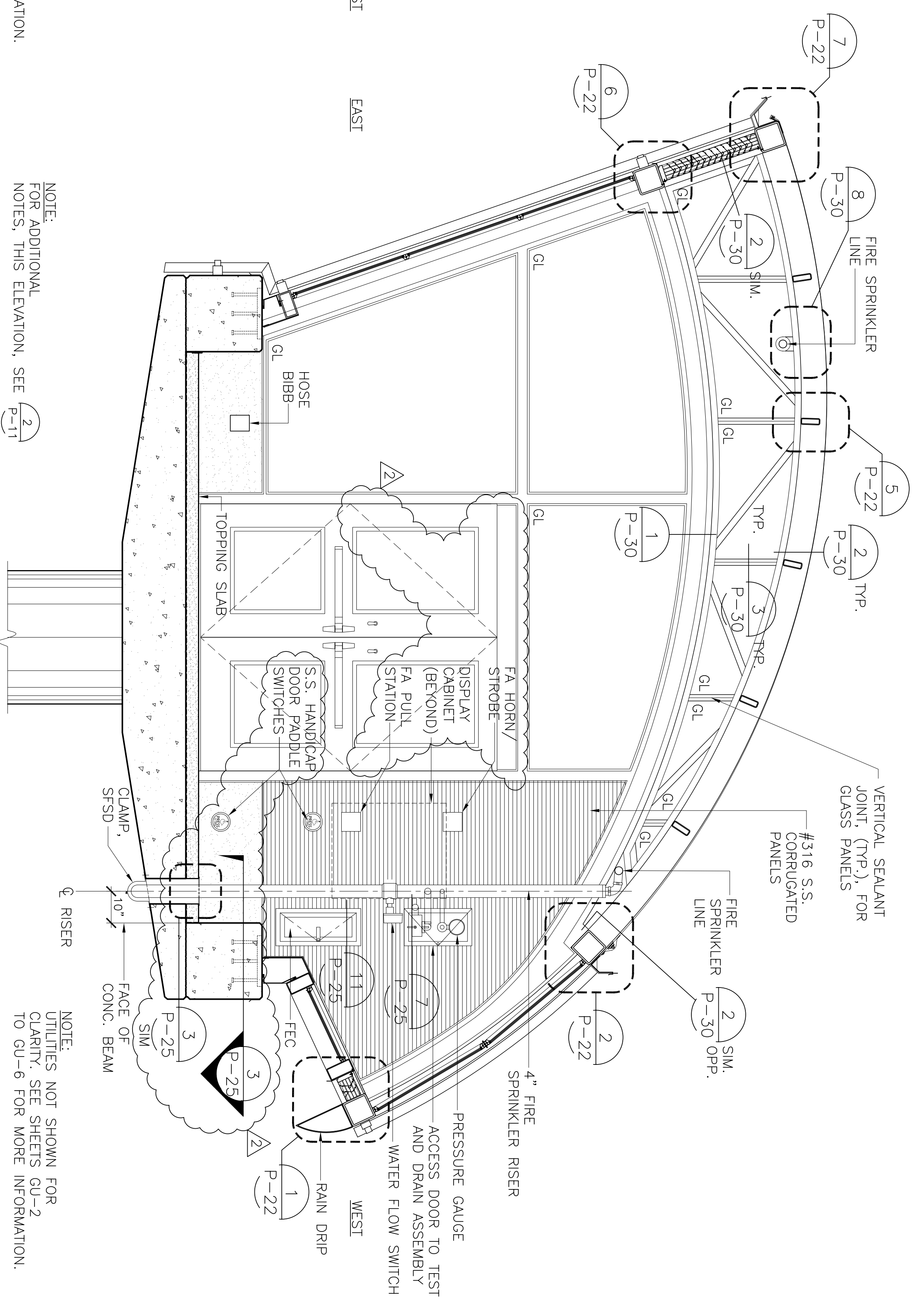

NOTE:
FOR ADDITIONAL
NOTES, THIS ELEVATION, SEE 

NOTE:
UTILITIES NOT SHOWN FOR
CLARITY. SEE SHEETS GU-2
TO GU-6 FOR MORE INFORMATION.

 PIER SOUTH ENTRY/EGRESS ELEVATION – LOOKING SOUTH @ GRIDLINE P1
SCALE 1/2" = 1'-0"

PRELIMINARY - NOT FOR CONSTRUCTION

REVISIONS	NO.	DATE	DESCRIPTION
	1	12/03/09	ADDENDUM 2
	2		



ROMA Design Group
Architects & Planners in association with
Moffatt & Nichol, Simpson Gumpertz & Heger Inc.,
Engineering Enterprises, Lund Engineering, and
Schlimer Engineering Corporation

CONSULTANT
SIMPSON GUMPERTZ & HEGER
Engineering of Structures
and Building Enclosures

SEAL/SIGNATURE

SEAL/SIGNATURE

DESIGNED BY:
BD
DRAWN BY:
TG
CHECKED BY:
JT

PROJECT
SOUTH SAN FRANCISCO FERRY TERMINAL
SHEET
**PIER SOUTH ENTRY/EGRESS
ELEVATIONS AT GRIDLINE P1**

DATE
11/10/2009
SHEET
40 OF
120
DRAWING NO.
P-11
JOB NO.
1348

ROMA owns all copyrights
and other intellectual
property rights in this work
product and it is protected
by federal and state copyright
laws. Any unauthorized
reproduction, distribution,
or use of this work without
written permission from
ROMA is prohibited. Refer to
the Project Manual for
applicable use restrictions.

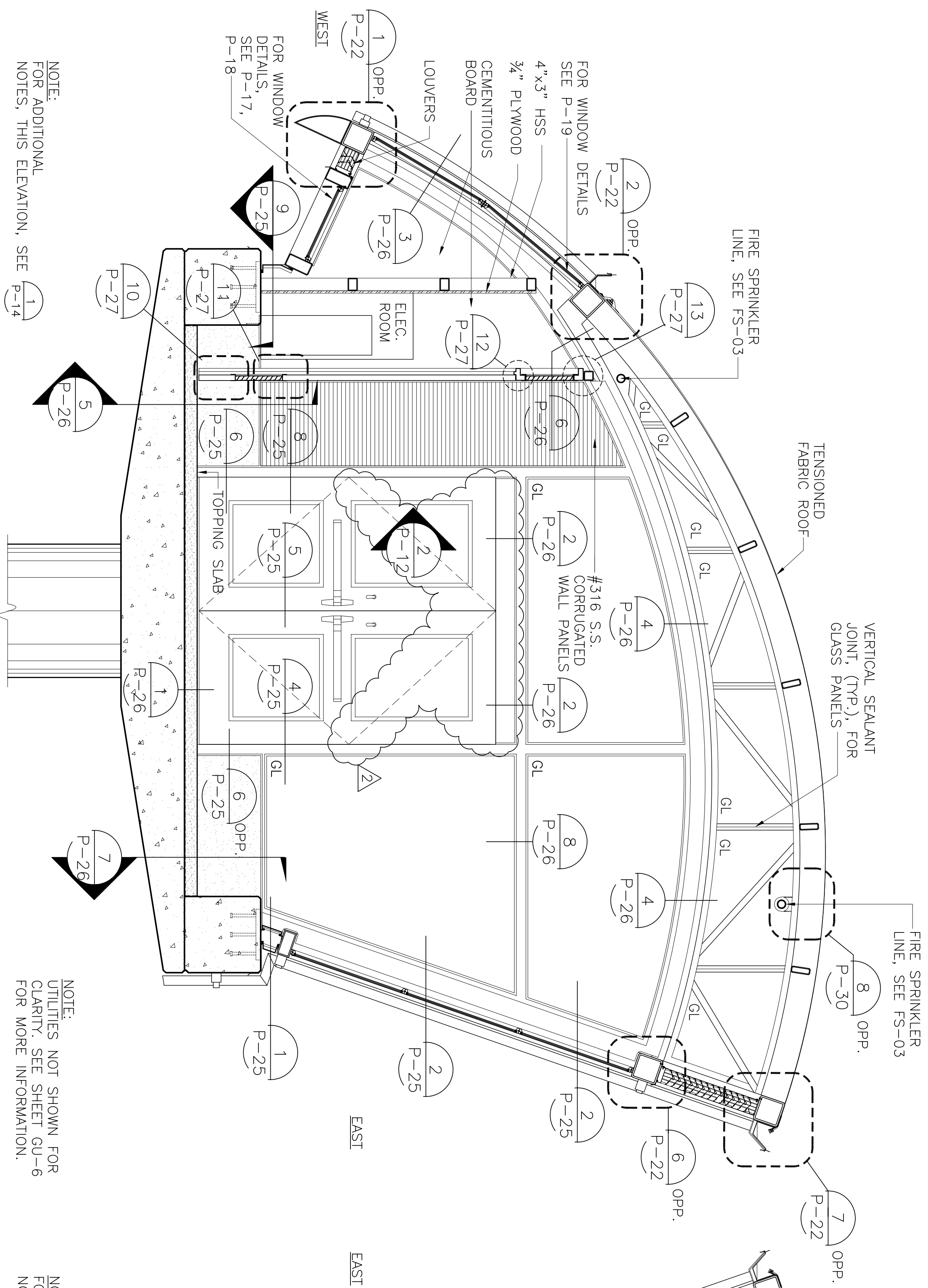

2 PIER SOUTH ENTRY/EGRESS ELEVATION – LOOKING NORTH @ GRIDLINE P10
SCALE 1/2" = 1'-0"

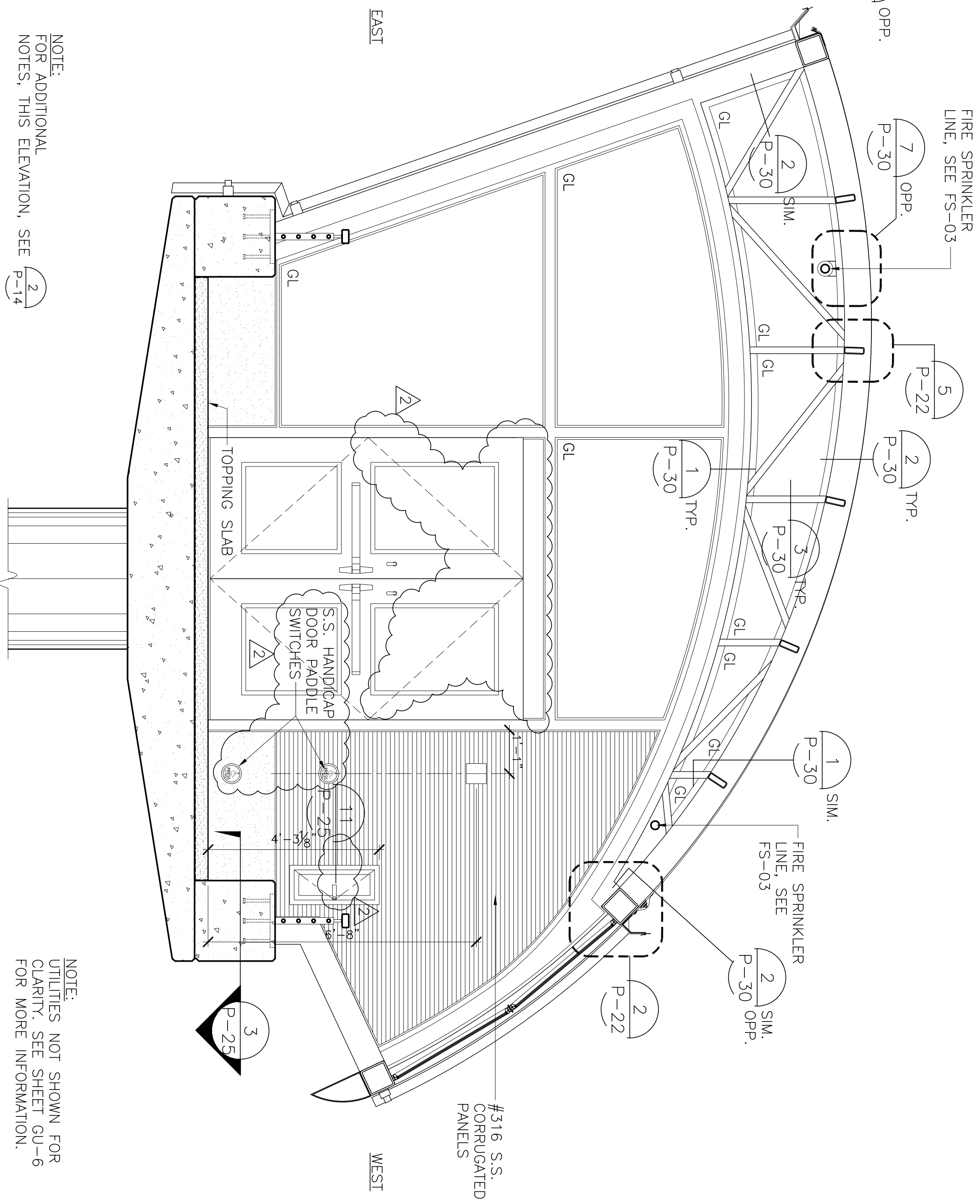

1 PIER SOUTH ENTRY/EGRESS ELEVATION – LOOKING SOUTH @ GRIDLINE P10
SCALE 1/2" = 1'-0"

PRELIMINARY - NOT FOR CONSTRUCTION

REVISIONS	NO.	DATE	DESCRIPTION
	1	12/03/09	ADDDENDUM 2



ROMA Design Group
Architects & Planners in association with
Moffatt & Nichol, Simpson Gumpertz & Heger Inc.,
Engineering Enterprises, Lund Engineering, and
Schlimer Engineering Corporation

CONSULTANT
SIMPSON GUMPERTZ & HEGER
Engineering of Structures
and Building Enclosures

SEAL/SIGNATURE

SEAL/SIGNATURE

DESIGNED BY:
BD
DRAWN BY:
TG
CHECKED BY:
JT

PROJECT
SOUTH SAN FRANCISCO FERRY TERMINAL
SHEET
**PIER INTERMEDIATE PARTITION
ELEVATIONS AT GRIDLINE P10**

DATE
11/10/2009
SHEET
43 OF 120
DRAWING NO.
P-14
JOB NO.
1348

ROMA owns all copyrights and other intellectual property rights in this work and it is protected by intellectual copyright law. Intellectual property rights in this work are hereby assigned to ROMA. Refer to the Project Manual for applicable use restrictions.

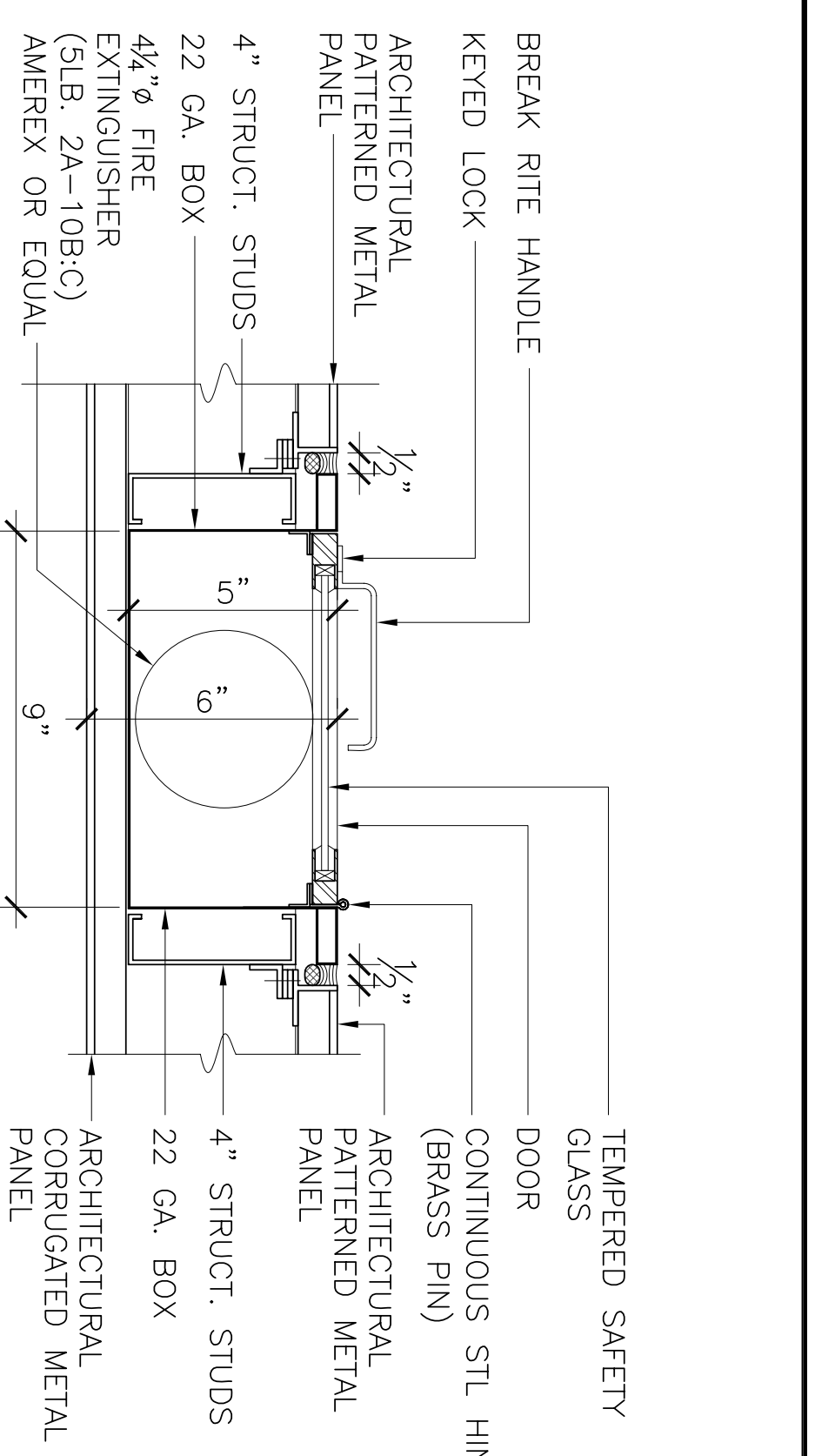

11 FIRE EXTINGUISHER CABINET
SCALE: 3" = 1'-0"

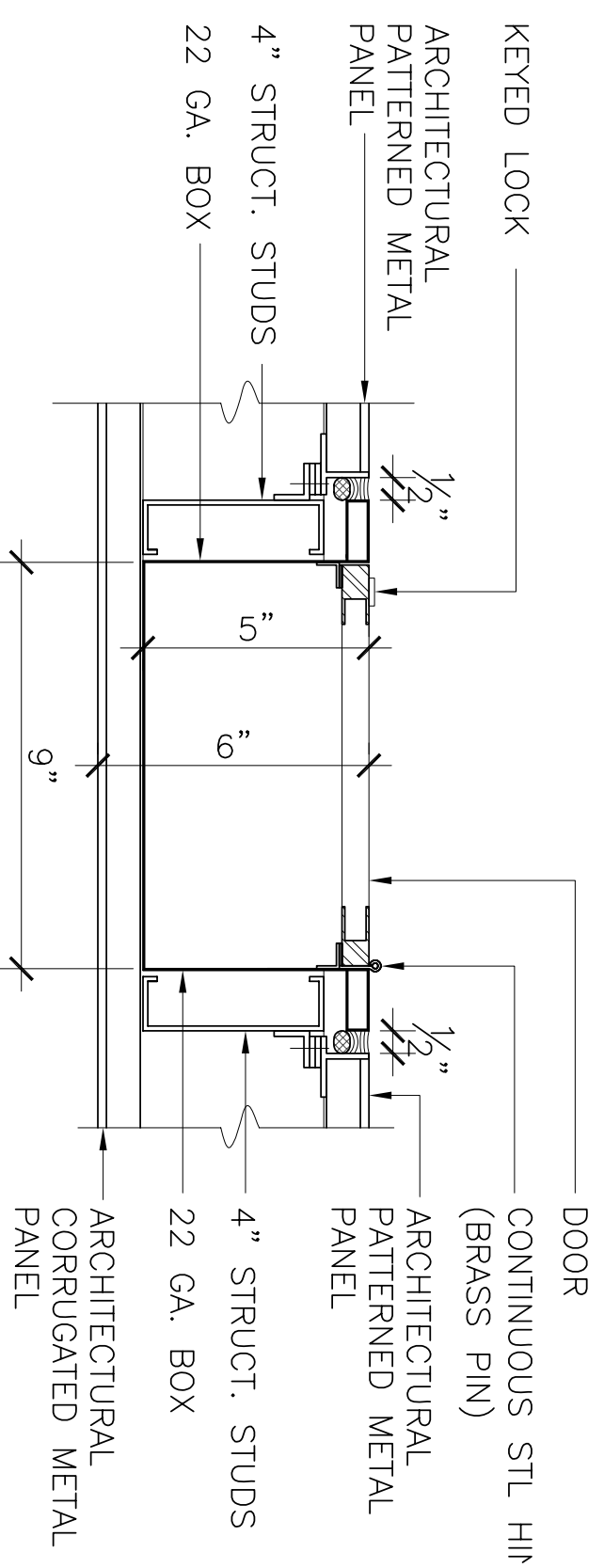

7 PRESSURE GAUGE & TEST AND DRAIN CABINET DETAIL
SCALE: 3" = 1'-0"

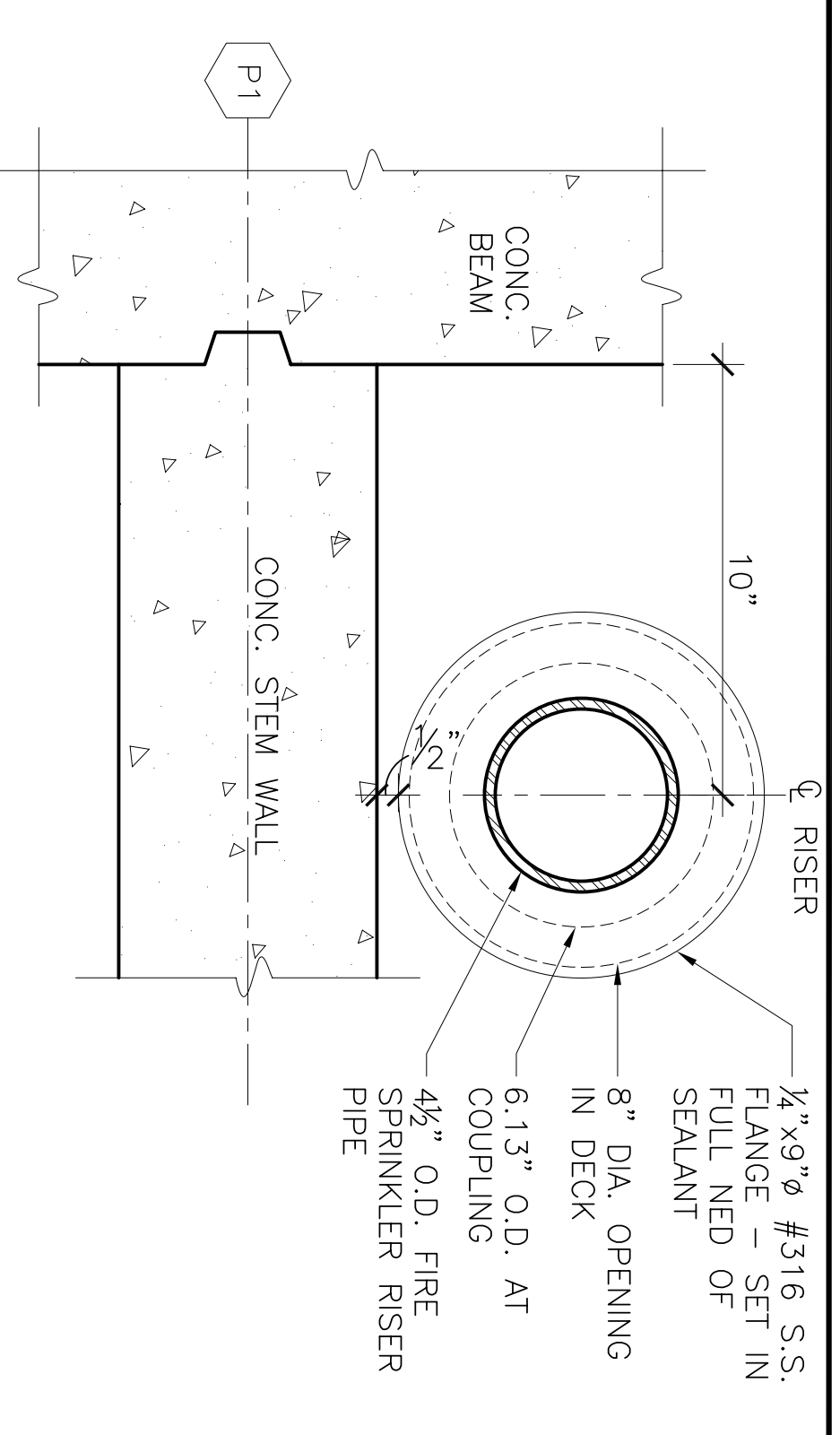

3 CONC. WALL @ FIRE SPRINKLER RISER PIPE
SCALE: 3" = 1'-0"

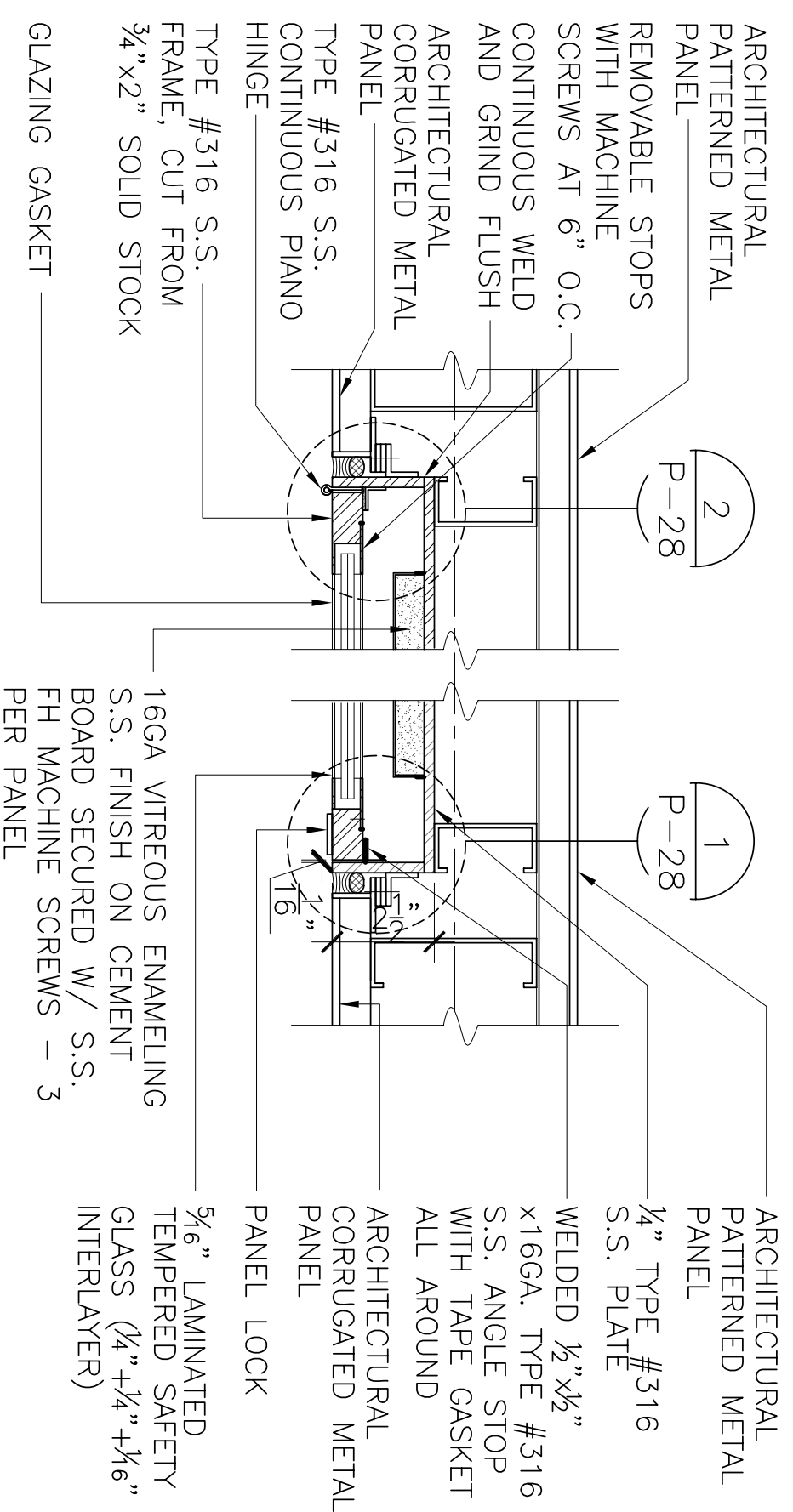

10 DISPLAY CABINET
SCALE: 3" = 1'-0"

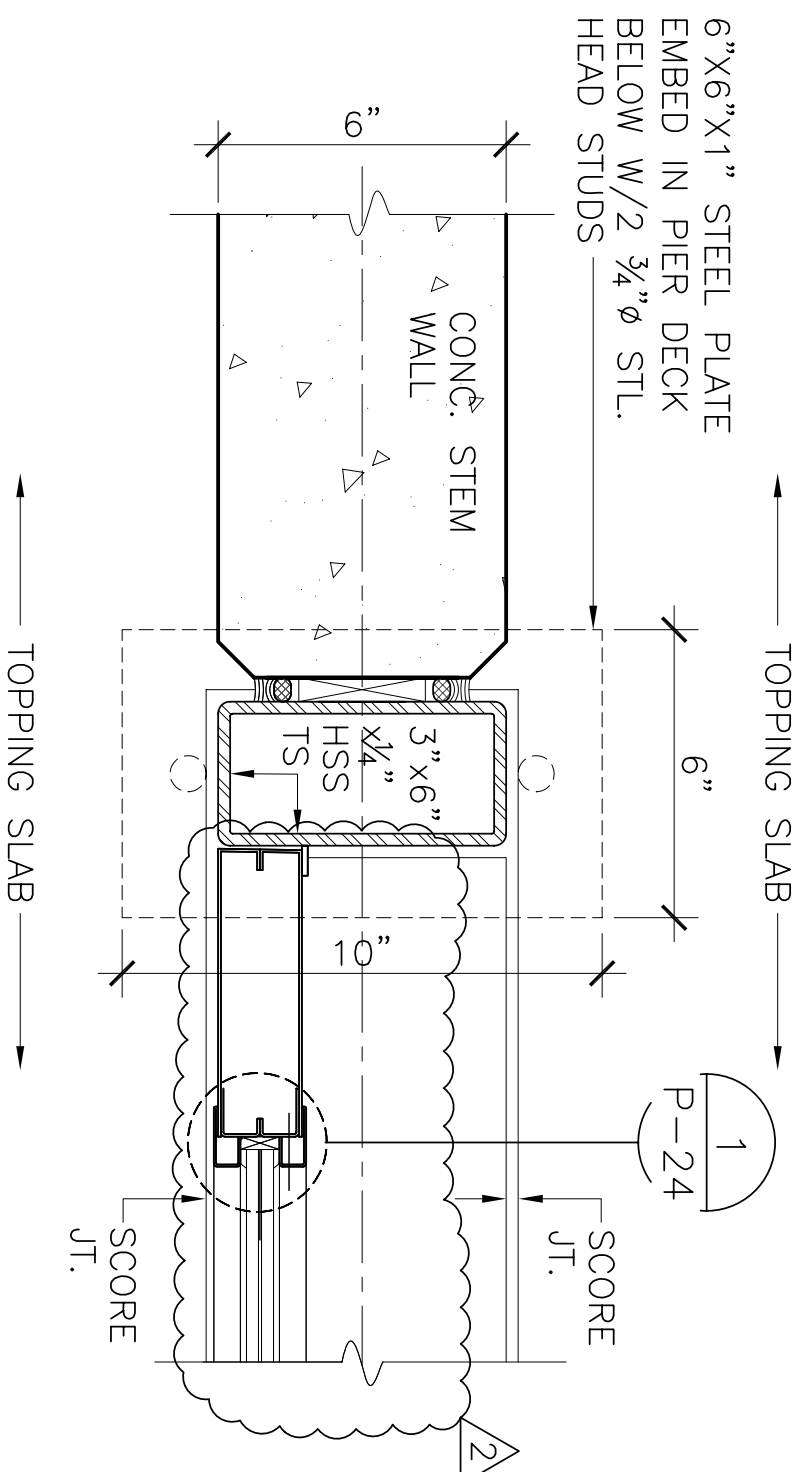

6 DOOR JAMB @ CONC. WALL
SCALE: 3" = 1'-0"

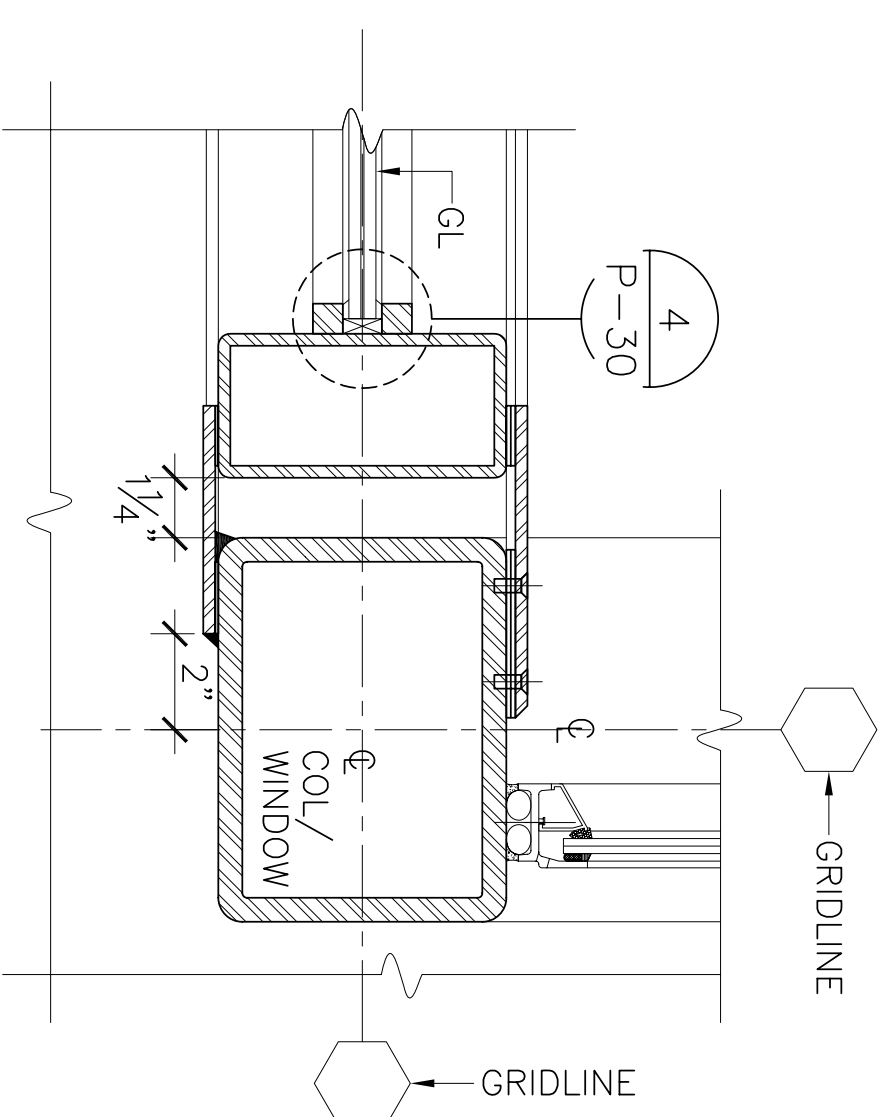

2 WINDOW/E.J. JAMB @ CONC. WALL
SCALE: 3" = 1'-0"

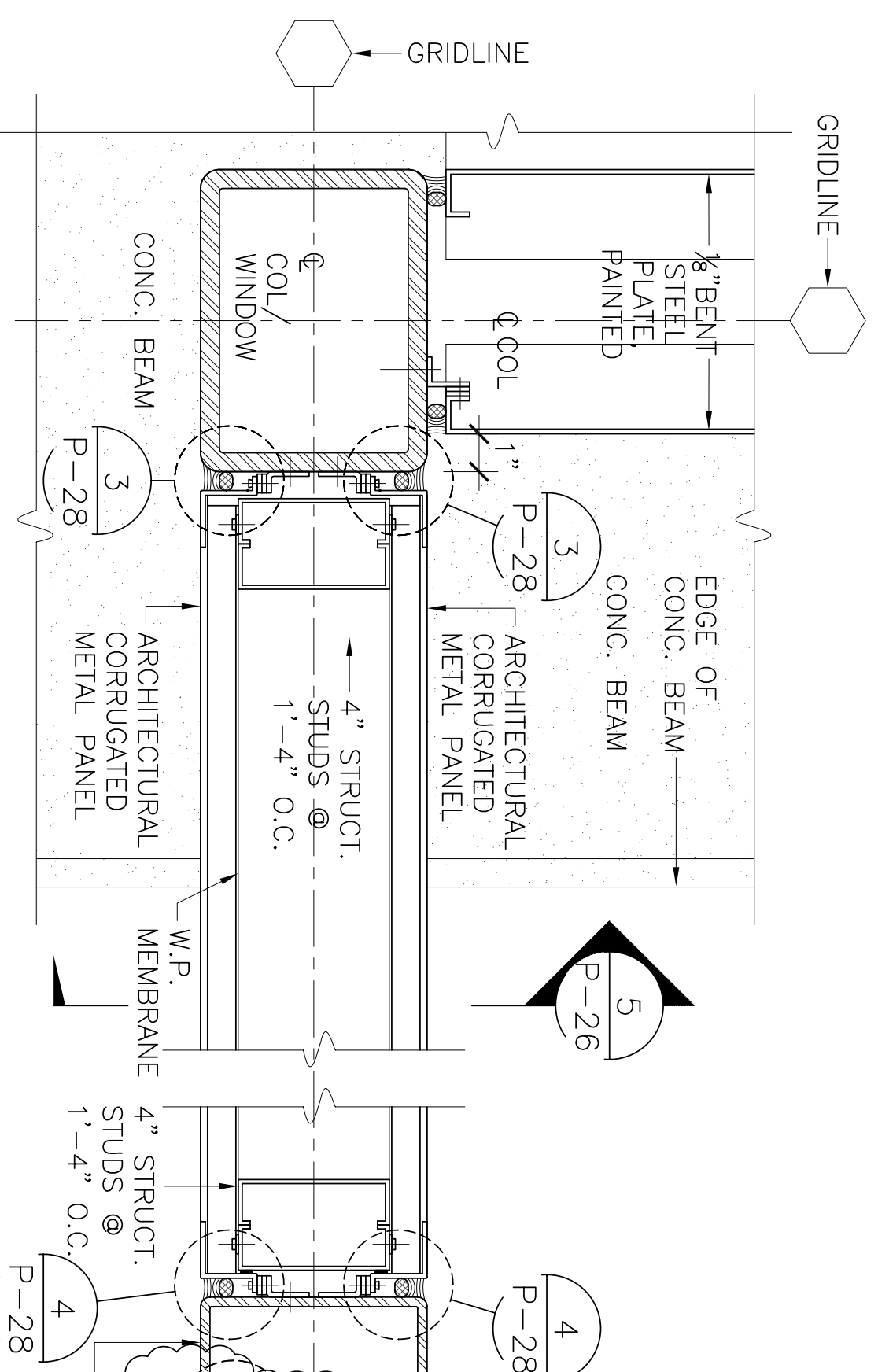

9 HSS COLUMN/PARTITION
SCALE: 3" = 1'-0"

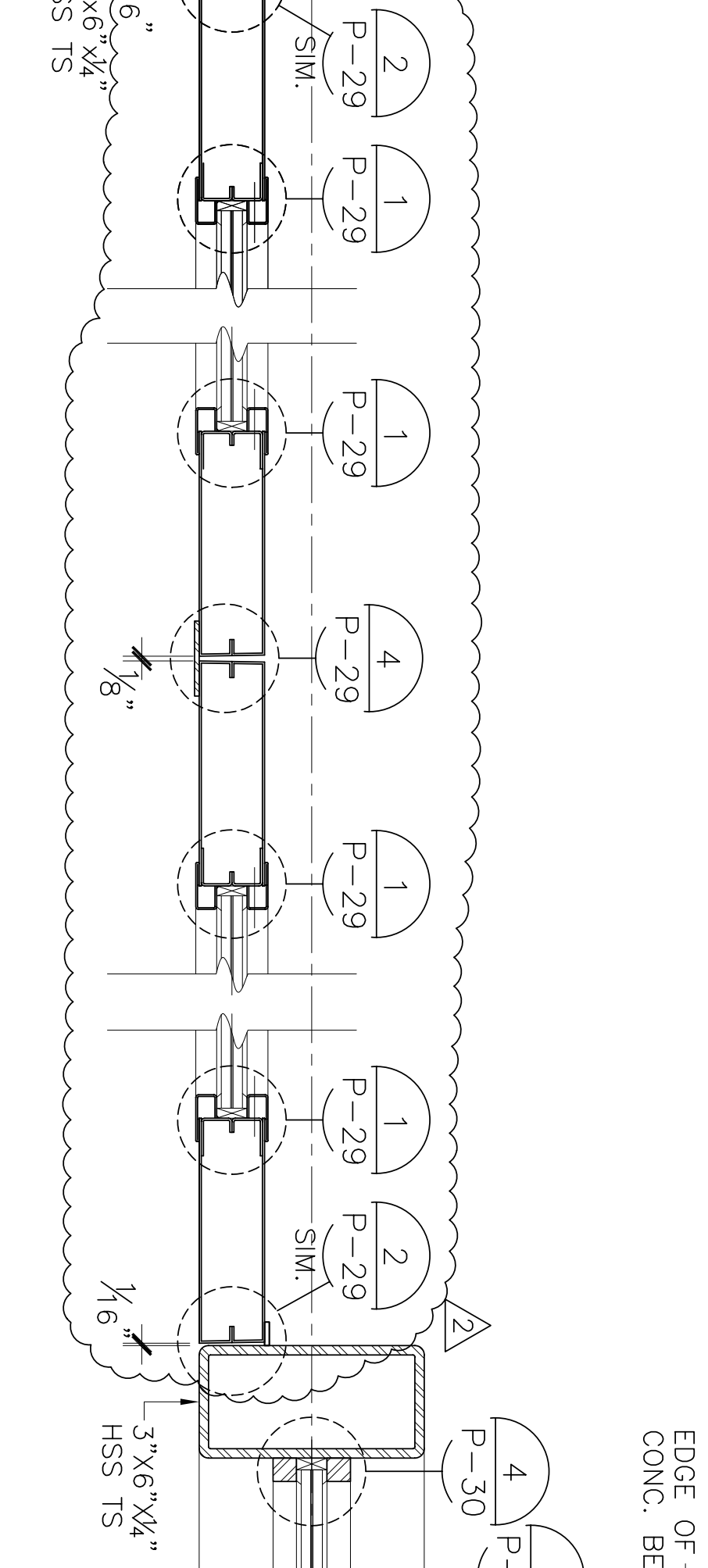

8 DOOR JAMB @ CORRUGATED PANELS
SCALE: 3" = 1'-0"

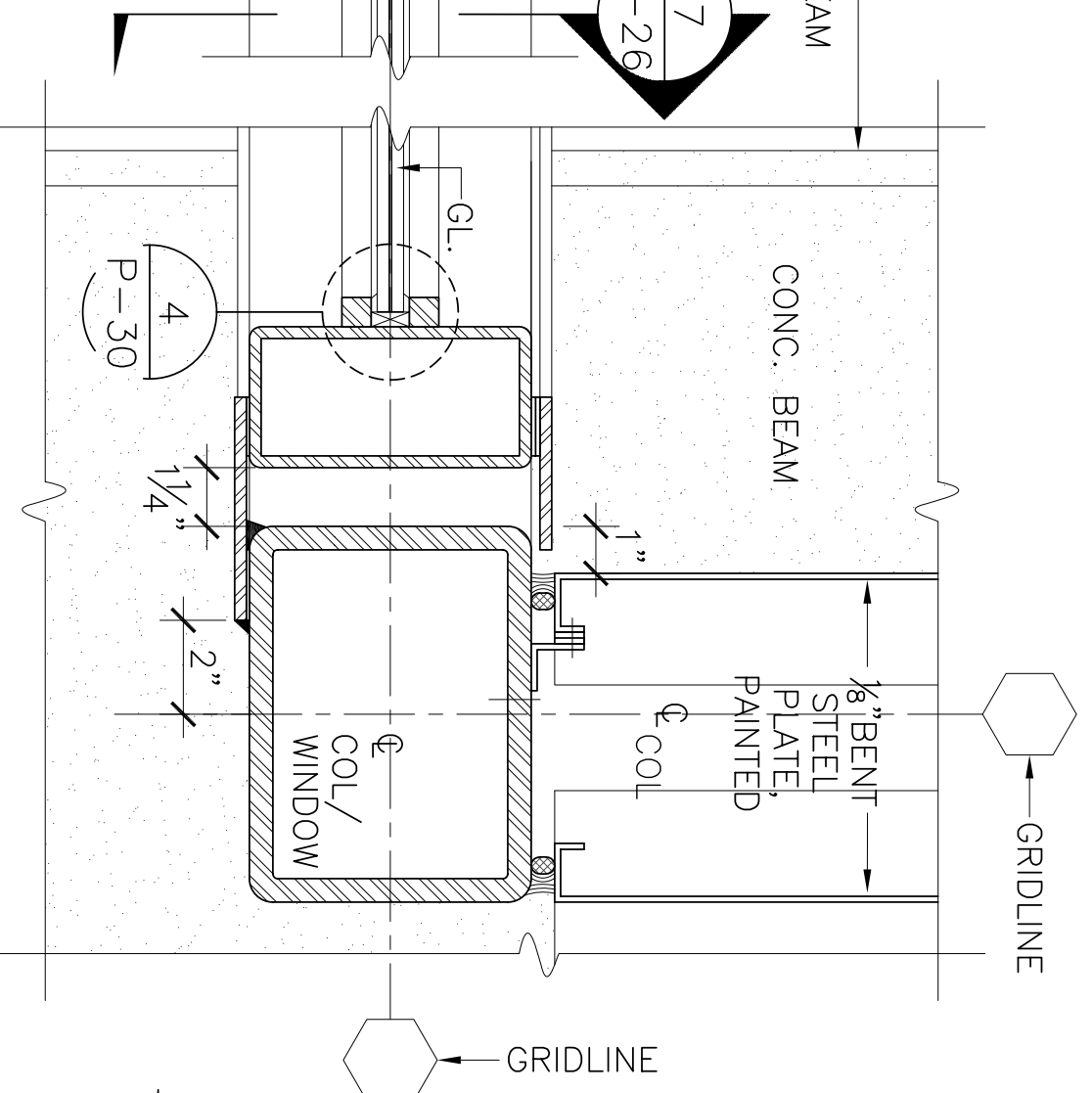

1 SLIP JOINT @ HSS COLUMN
SCALE: 3" = 1'-0"

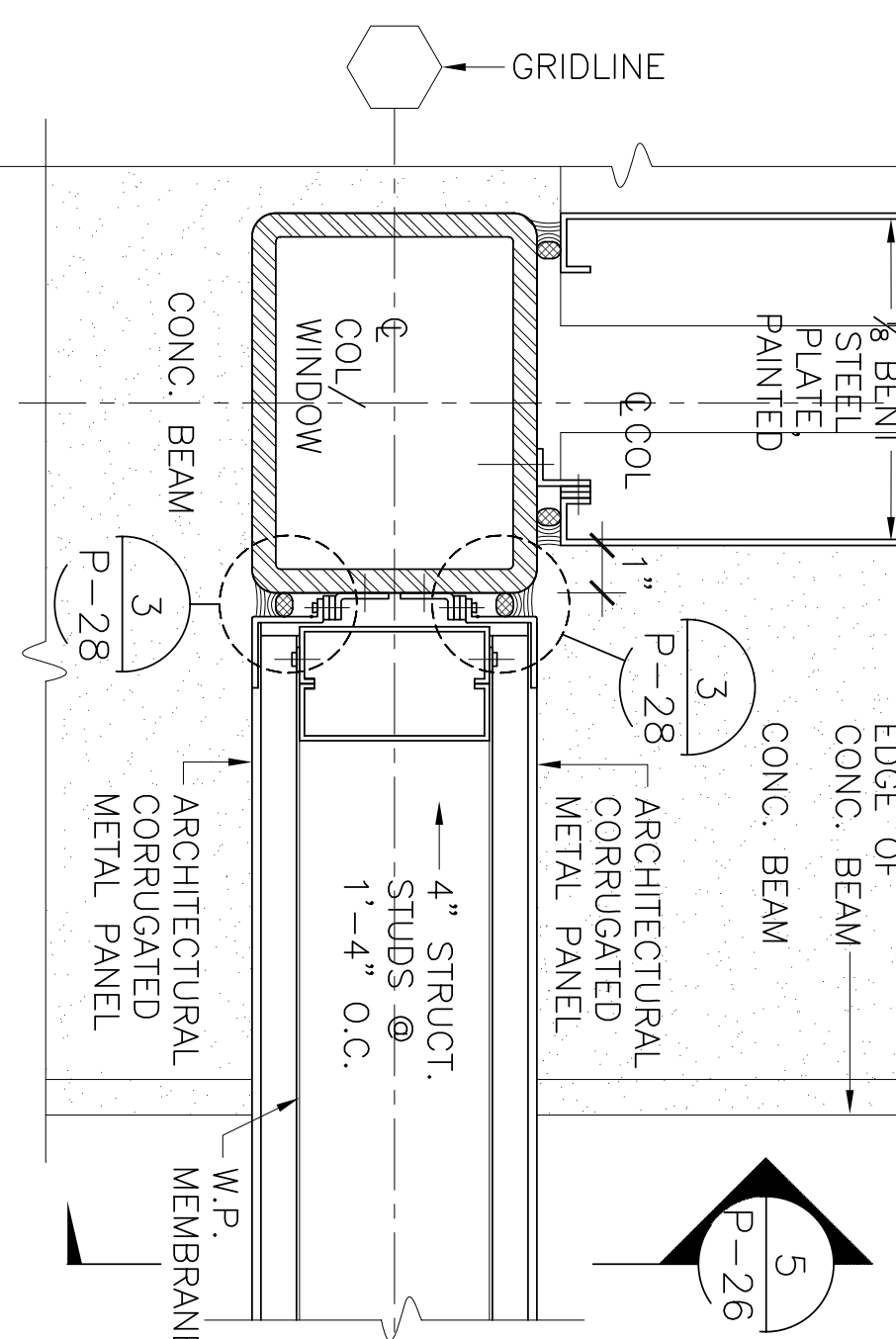

5 ASTRAGAL @ DOORS
SCALE: 3" = 1'-0"

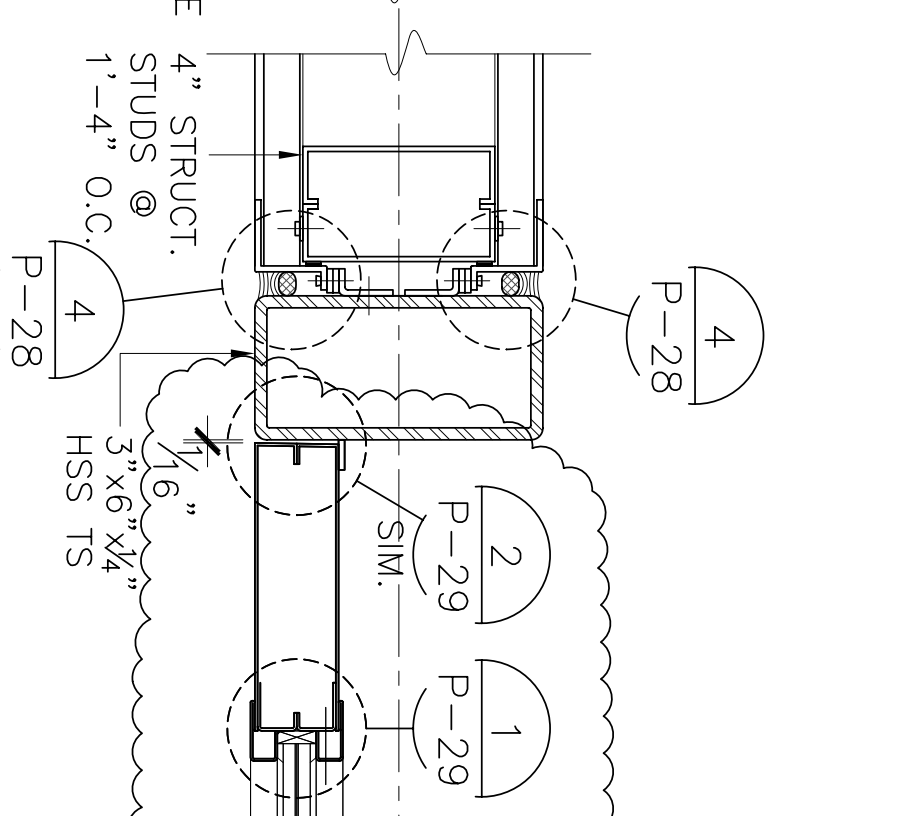

4 DOOR JAMB @ GLASS
SCALE: 3" = 1'-0"

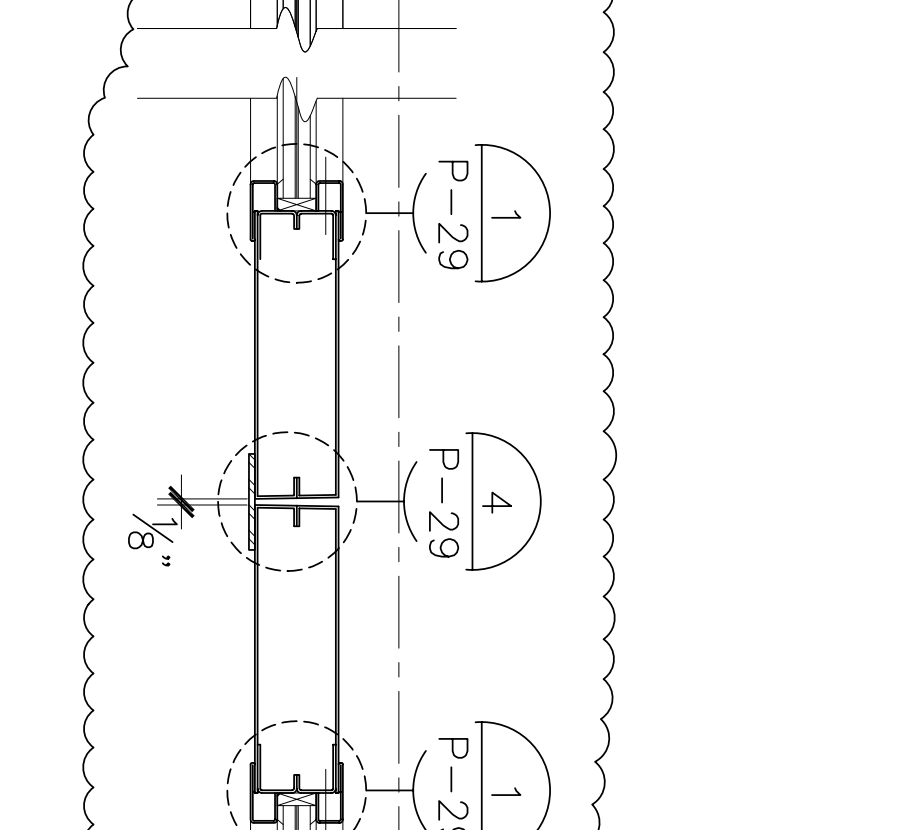

5 ASTRAGAL @ DOORS
SCALE: 3" = 1'-0"

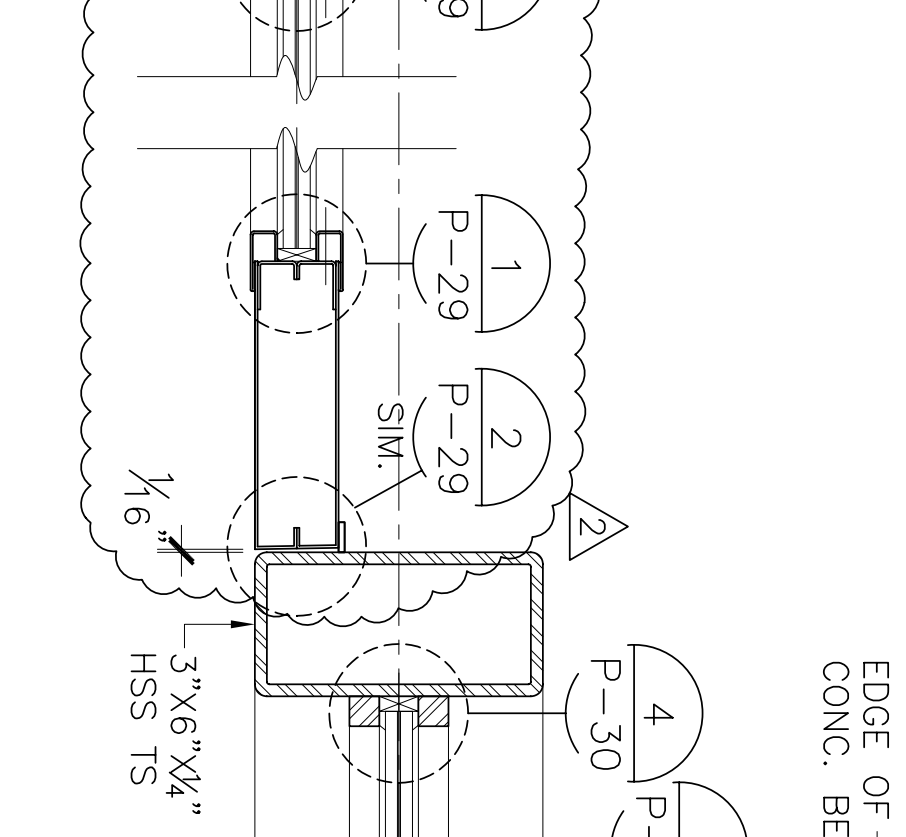

4 DOOR JAMB @ GLASS
SCALE: 3" = 1'-0"

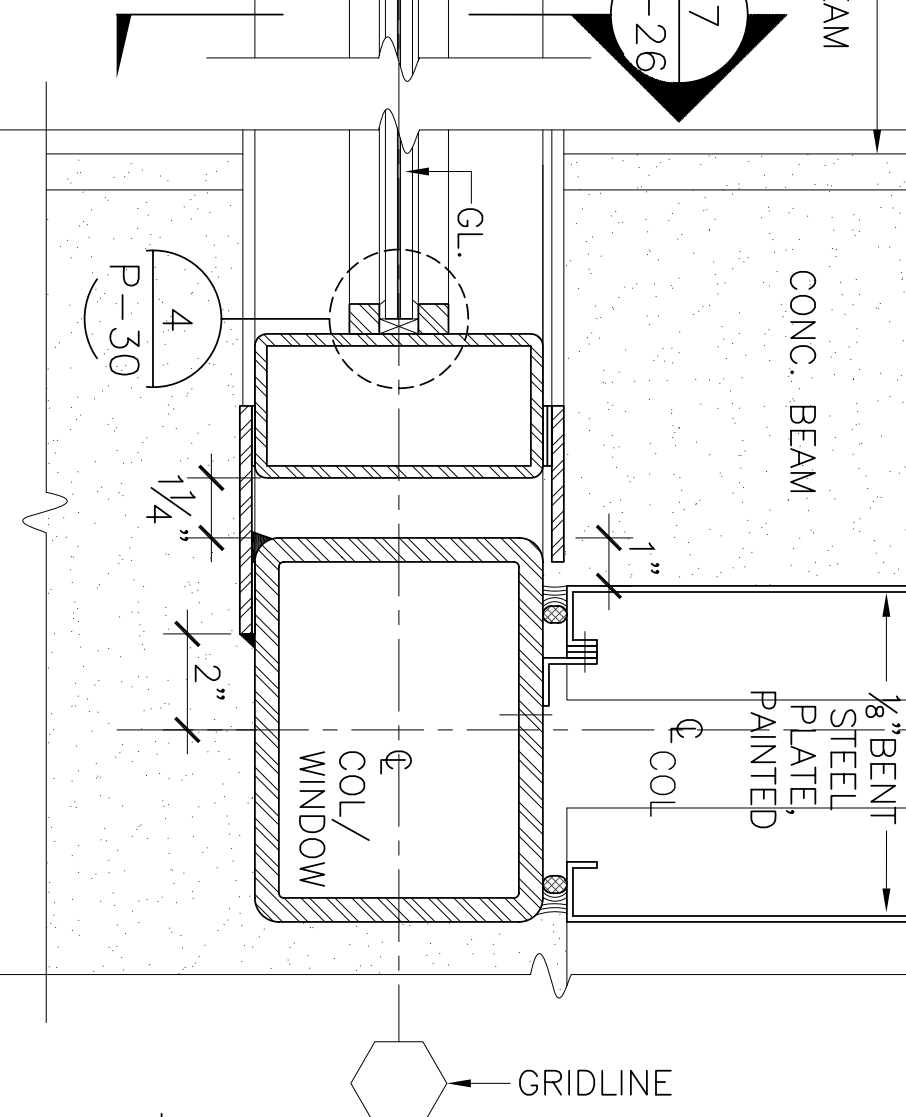

1 SLIP JOINT @ HSS COLUMN
SCALE: 3" = 1'-0"

NOTE:
SEE SPECIFICATION SECTION
08800, HARDWARE, FOR
HARDWARE SET(S) FOR DOORS.

PRELIMINARY - NOT FOR CONSTRUCTION

NO.	DATE	DESCRIPTION
1	12/03/09	ADDENDUM 2



ROMA Design Group
Architects & Planners in association with
Moffatt & Nichol, Simpson Gumpertz & Heger Inc.,
Engineering Enterprises, Lund Engineering, and
Schlimer Engineering Corporation

CONSULTANT
SIMPSON GUMPERTZ & HEGER
Engineering of Structures
and Building Enclosures

DESIGNED BY: BD
DRAWN BY: KL
CHECKED BY: JT

PROJECT
SOUTH SAN FRANCISCO FERRY TERMINAL
PIER PARTITION AND DOOR DETAILS

DATE
11/10/2009
SHEET
54 OF 120
DRAWING NO.
P-25
JOB NO.
1348

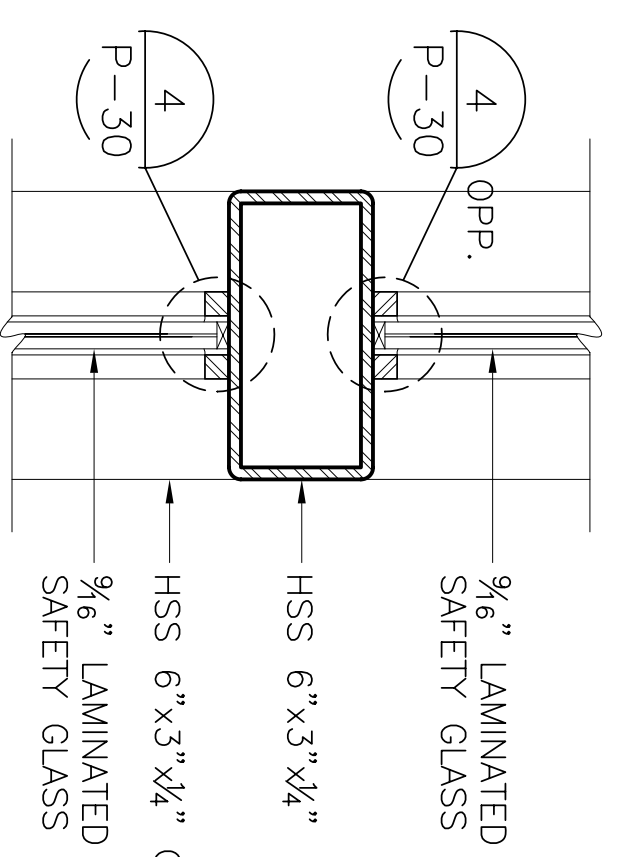

8 GLASS WALL MULLION
SCALE: 3" = 1'-0"

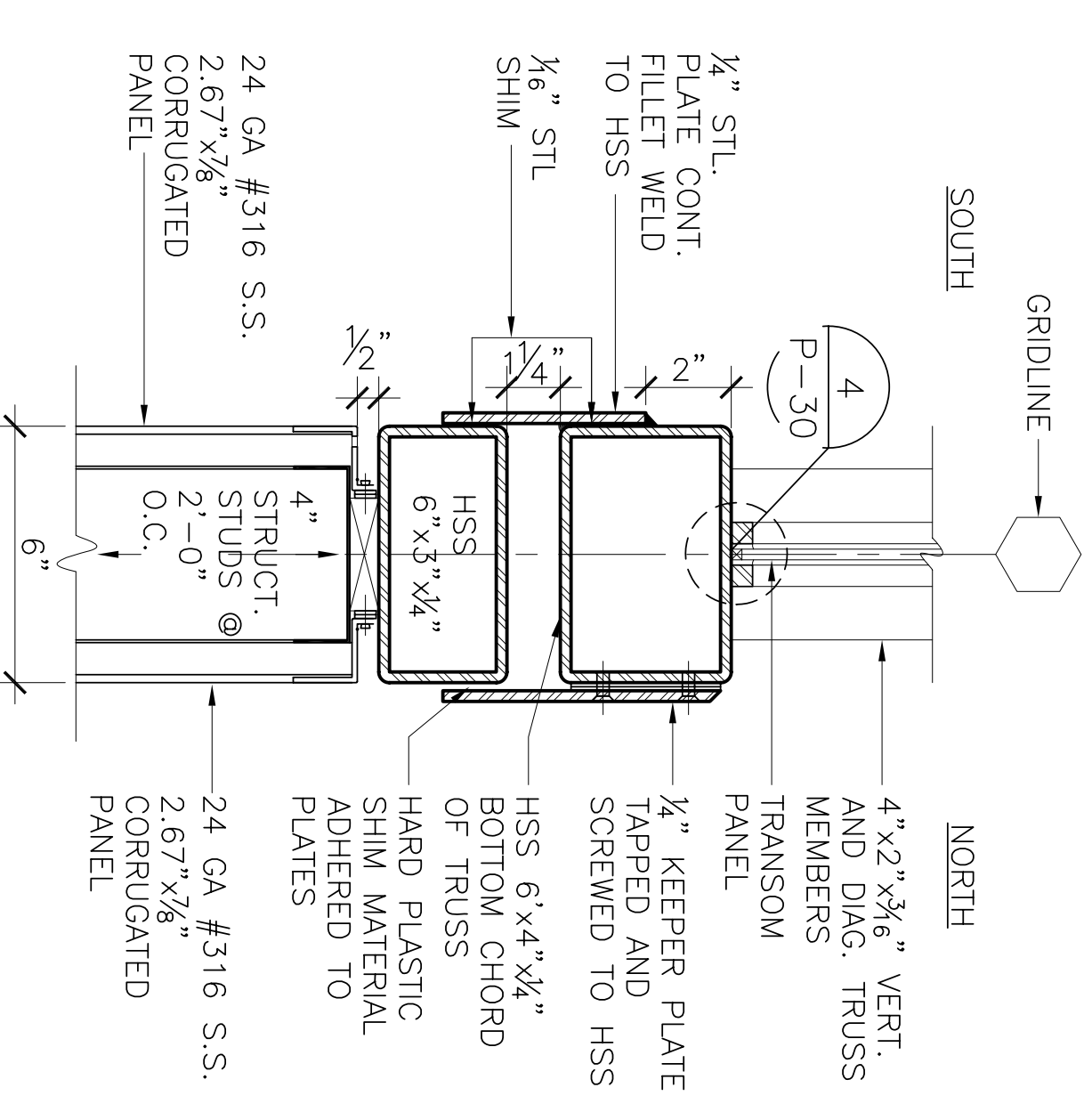

6 METAL WALL SLIP JOINT @
BOT. CHORD OF BOW TRUSS
SCALE: 3" = 1'-0"

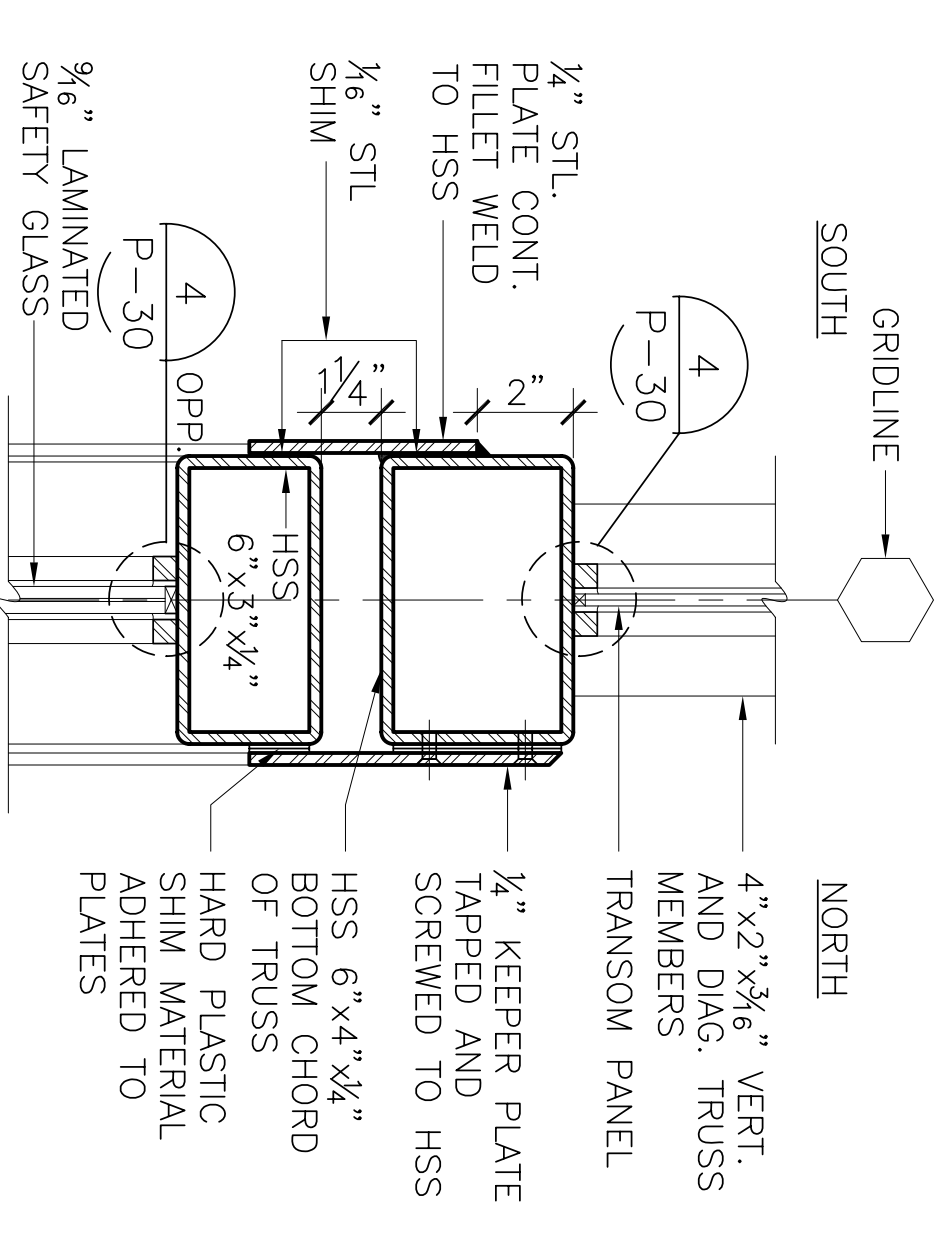

4 GLASS WALL SLIP JOINT @
BOT. CHORD OF BOW TRUSS
SCALE: 3" = 1'-0"

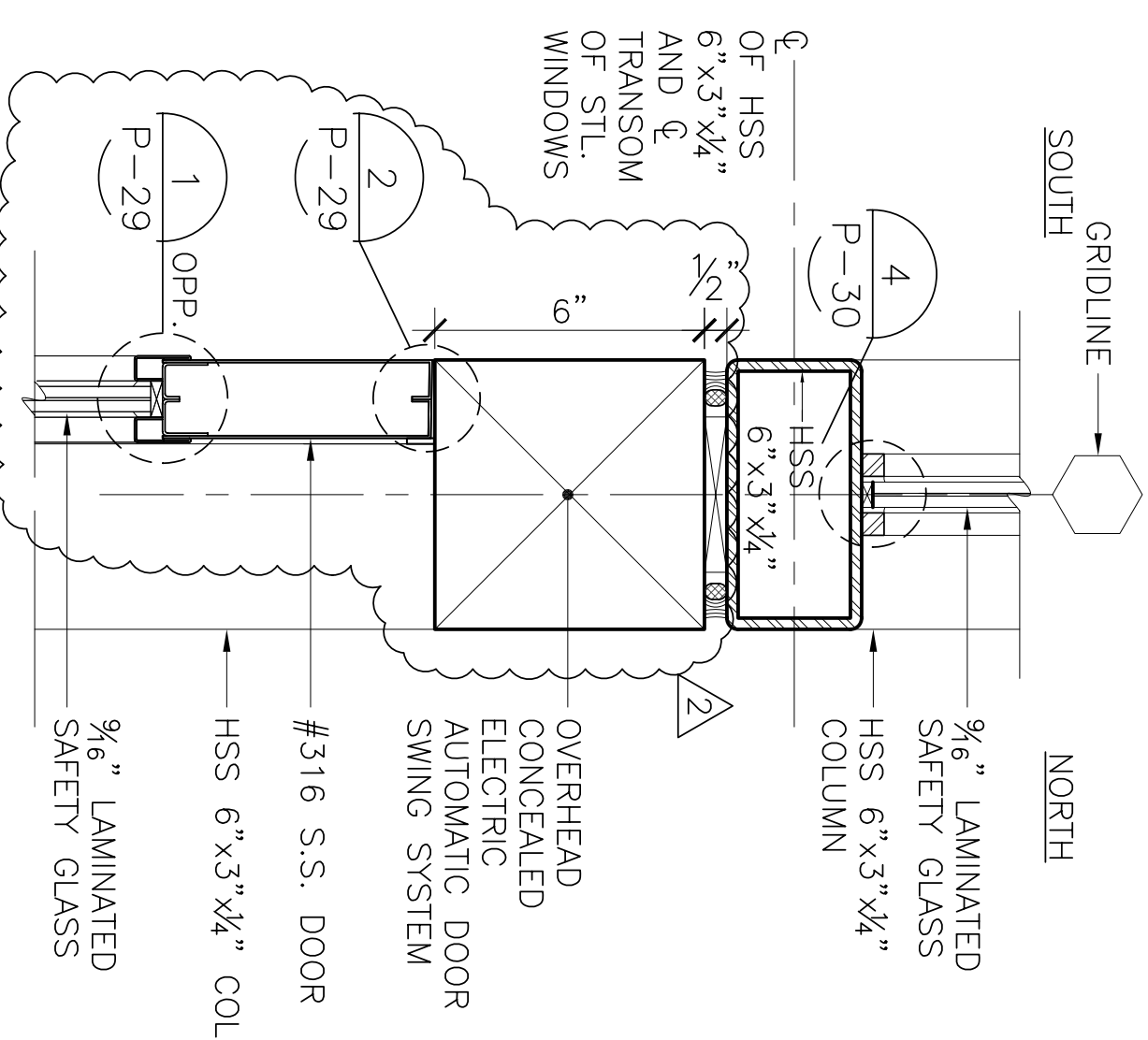

2 HEAD @ S.S. DOOR SECTION
SCALE: 3" = 1'-0"

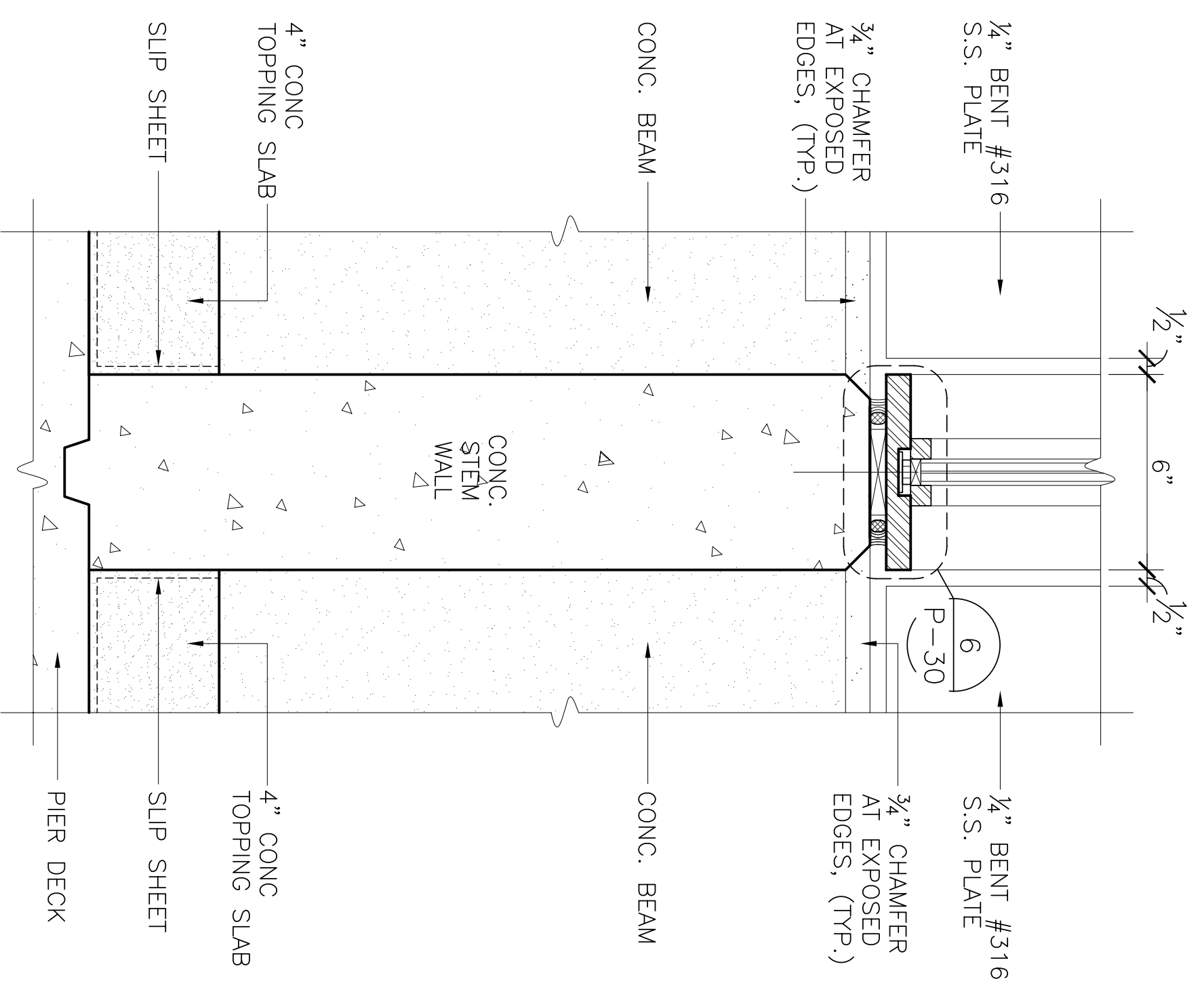

7 CONCRETE STEM WALL @ GLASS PANELS
SCALE: 3" = 1'-0"

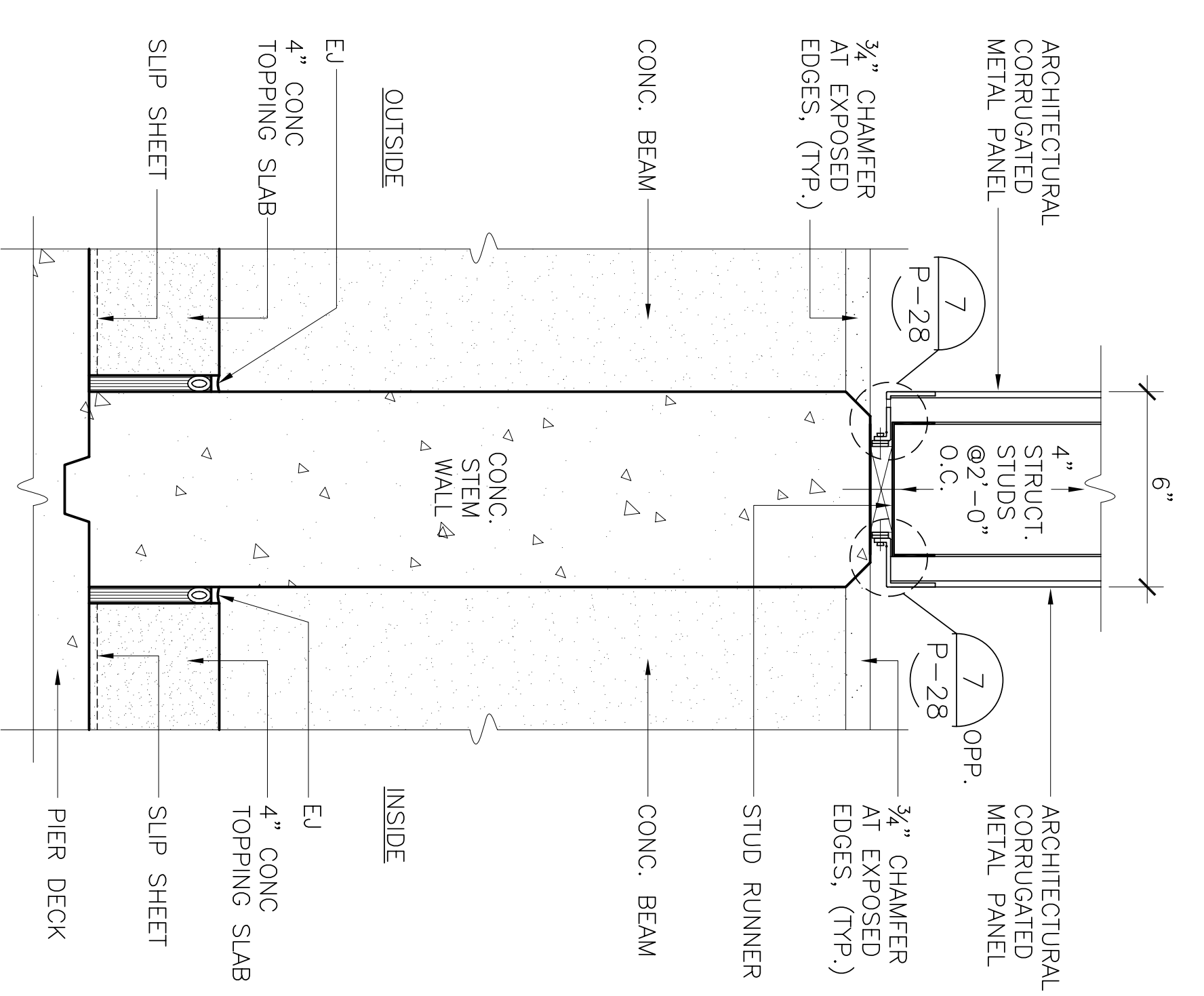

5 CONCRETE STEM WALL @ METAL PANELS
SCALE: 3" = 1'-0"

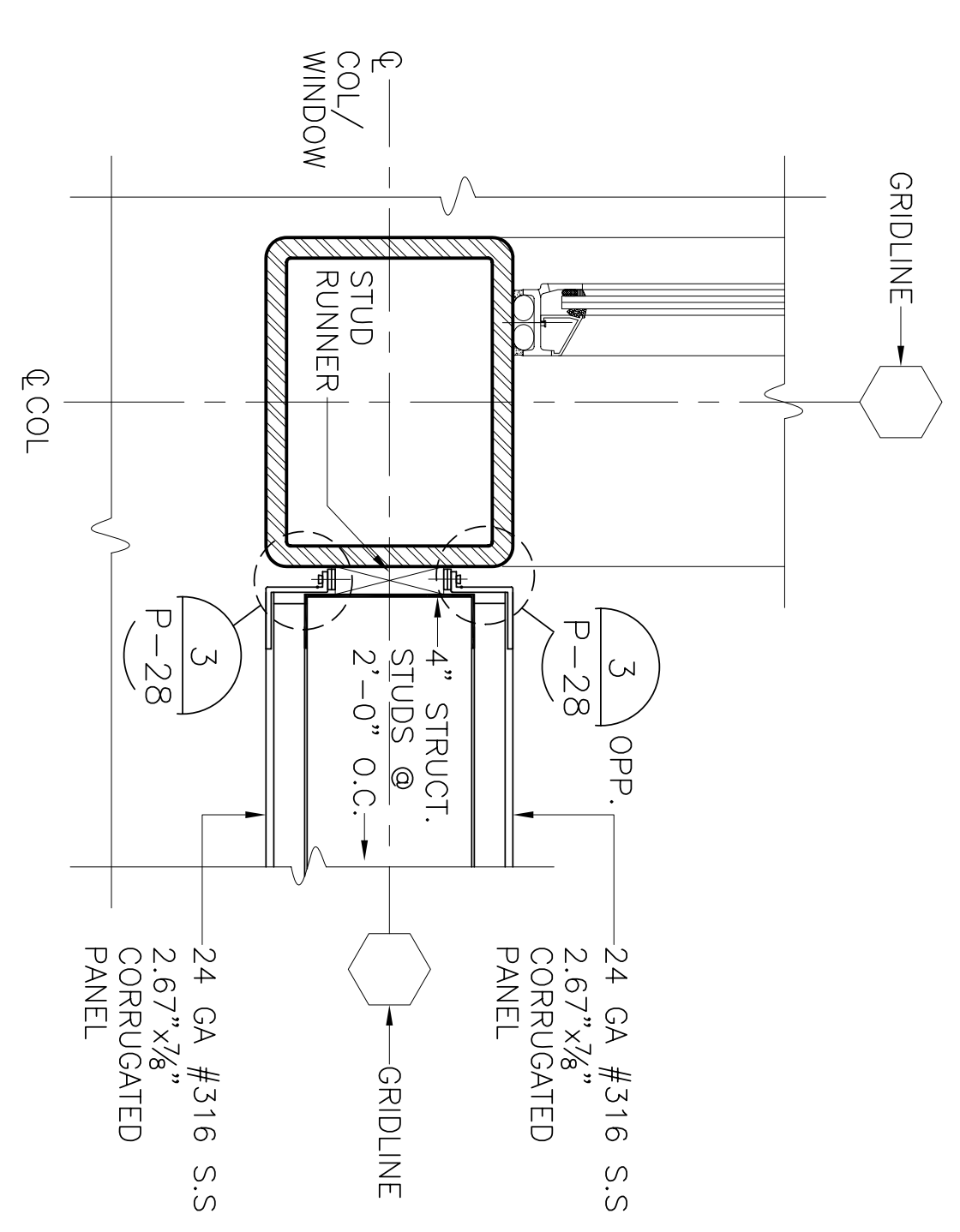

3 HSS COLUMN @ GLASS & PARTITION
SCALE: 3" = 1'-0"

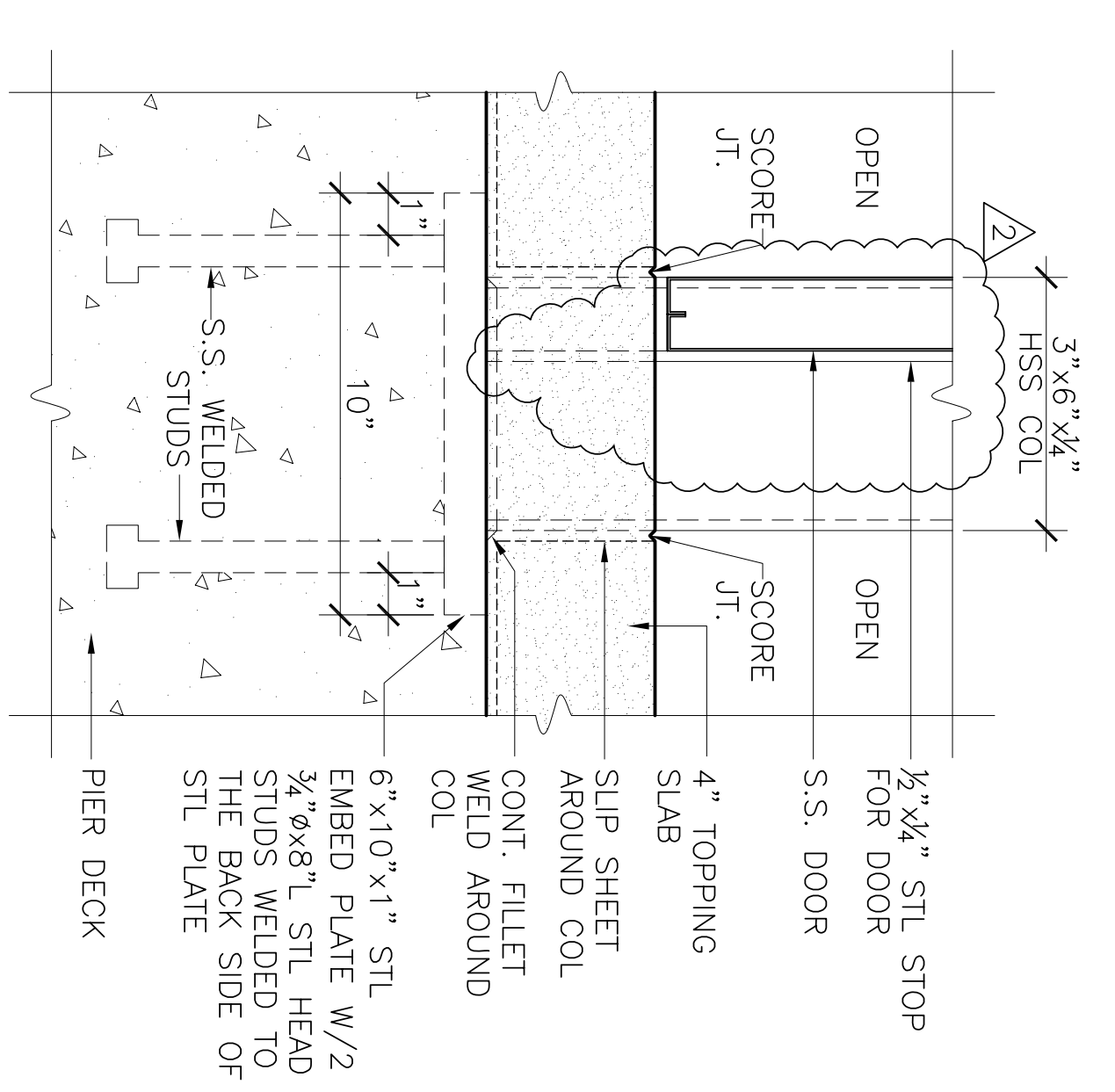

1 SILL @ S.S. DOOR
SCALE: 3" = 1'-0"

PRELIMINARY - NOT FOR CONSTRUCTION

NO.	DATE	DESCRIPTION
1	12/03/09	ADDENDUM 2



ROMA Design Group
Architects & Planners in association with
Moffatt & Nichol, Simpson Gumpertz & Heger Inc.,
Engineering Enterprises, Lund Engineering, and
Schlimer Engineering Corporation

CONSULTANT
SIMPSON GUMPERTZ & HEGER
Engineering of Structures
and Building Enclosures

SEAL/SIGNATURE

SEAL/SIGNATURE

DESIGNED BY:
BD
DRAWN BY:
KL
CHECKED BY:
JT

PROJECT
SOUTH SAN FRANCISCO FERRY TERMINAL
PIER PARTITION AND DOOR DETAILS

DATE
11/10/2009
SHEET
55 OF 120
DRAWING NO.
P-26
JOB NO.
1348

ROMA owns all copyrights and other intellectual property rights in this work product and it is protected by intellectual property laws. No third party may reproduce, copy, or otherwise use this work product without the prior written consent of ROMA. For more information, refer to the Project Manual for applicable use restrictions.

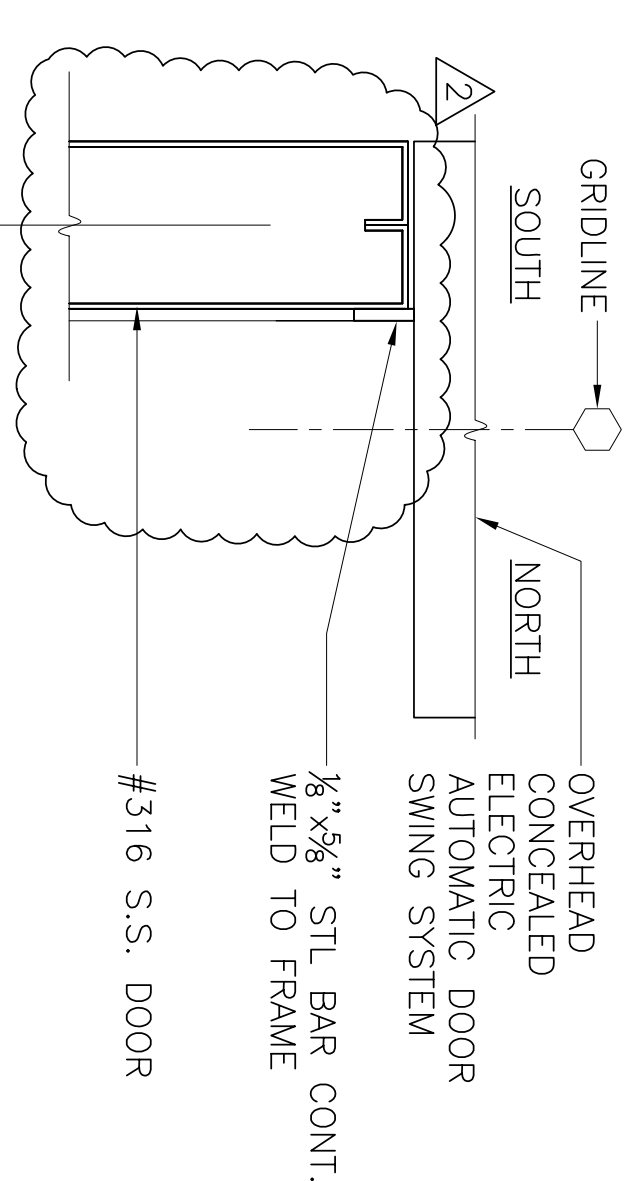

2 DOOR HEAD DETAIL
SCALE: 6" = 1'-0"

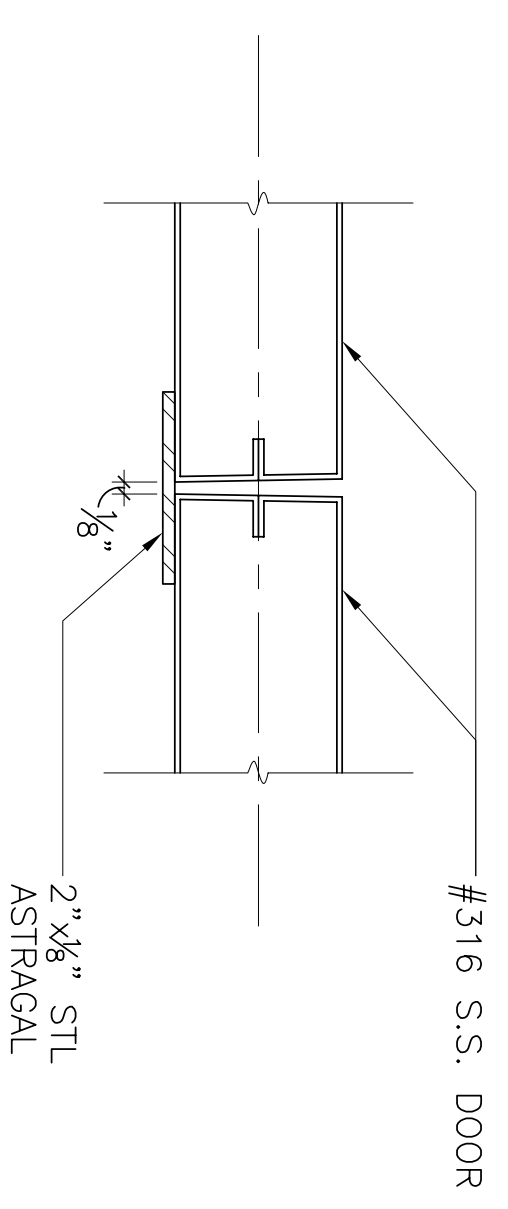

4 DETAIL @ ASTRAGAL
SCALE: 6" = 1'-0"

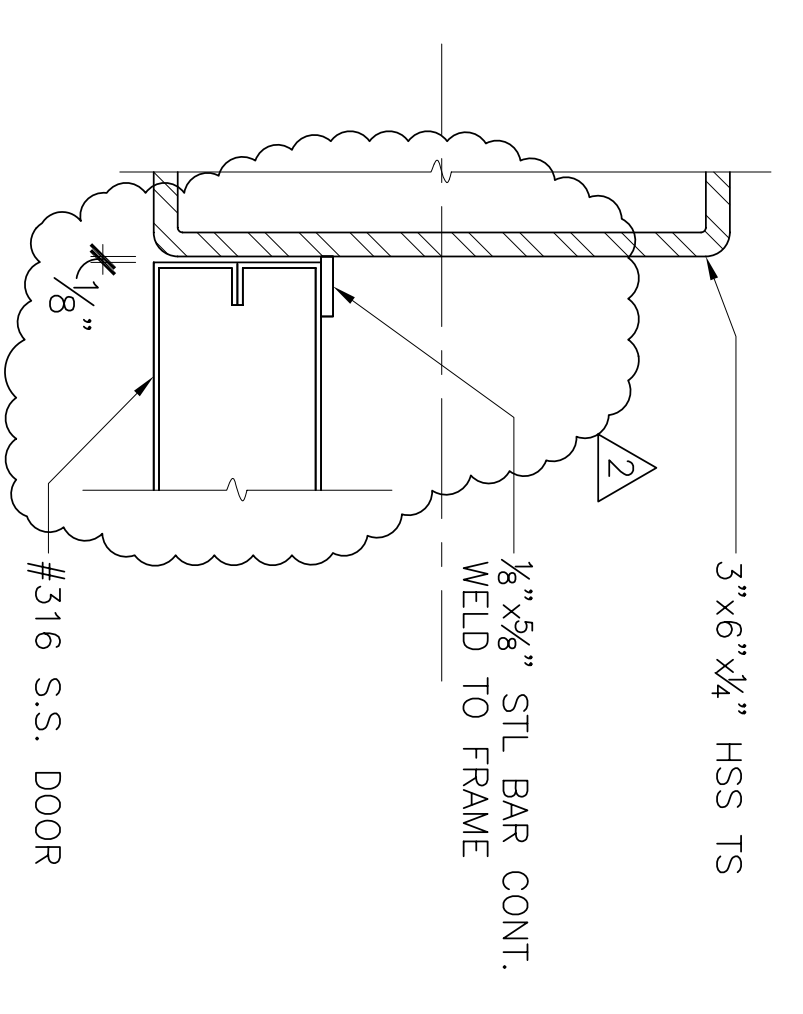

3 DOOR JAMB
SCALE: 6" = 1'-0"

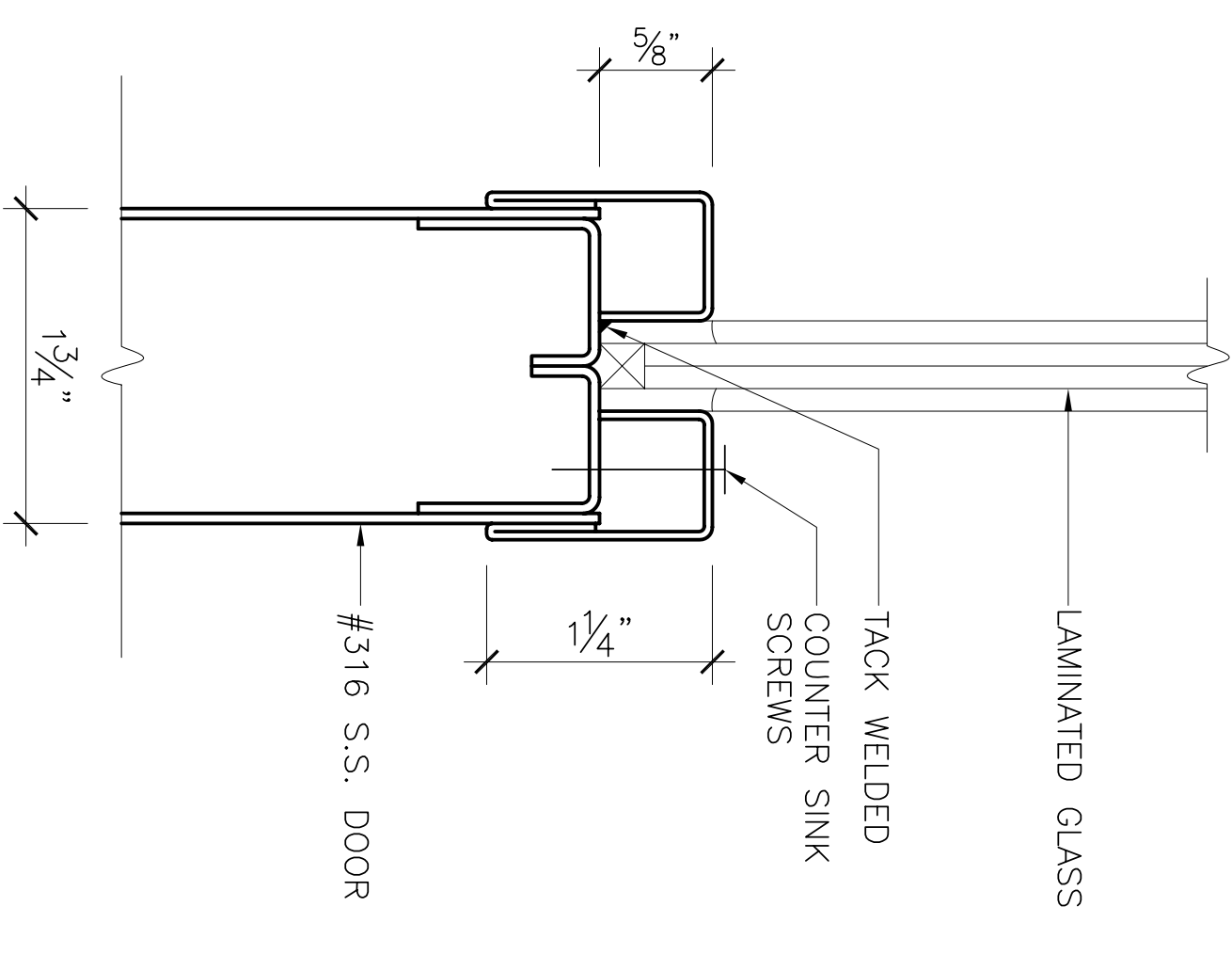

1 GLASS STOP @ DOOR
SCALE: FULLSIZE

PRELIMINARY - NOT FOR CONSTRUCTION

NO.	DATE	DESCRIPTION
1	12/03/09	ADDENDUM 2



ROMA Design Group
Architects & Planners in association with
Moffatt & Nichol, Simpson Gumpertz & Heger Inc.,
Engineering Enterprises, Lund Engineering, and
Schirmer Engineering Corporation

CONSULTANT
SIMPSON GUMPERTZ & HEGER
Engineering of Structures
and Building Enclosures

SEAL/SIGNATURE

SEAL/SIGNATURE

DESIGNED BY:
BD

DRAWN BY:
KL

CHECKED BY:
JT

PROJECT
SOUTH SAN FRANCISCO FERRY TERMINAL

SHEET
PIER DOOR DETAILS

DATE
11/10/2009

SHEET
58 OF **120**

DRAWING NO.
P-29

JOB NO.
1348

ROMA owns all copyrights and other intellectual property rights in this work product and it is protected by applicable copyright law. Intellectual property rights in this work product are reserved. Refer to the Project Manual for applicable use restrictions.